

# Service Manual

**Feeder**

**DADF-L1**

**Canon**

Nov 13 2003



## Application

This manual has been issued by Canon Inc. for qualified persons to learn technical theory, installation, maintenance, and repair of products. This manual covers all localities where the products are sold. For this reason, there may be information in this manual that does not apply to your locality.

## Corrections

This manual may contain technical inaccuracies or typographical errors due to improvements or changes in products. When changes occur in applicable products or in the contents of this manual, Canon will release technical information as the need arises. In the event of major changes in the contents of this manual over a long or short period, Canon will issue a new edition of this manual.

The following paragraph does not apply to any countries where such provisions are inconsistent with local law.

## Trademarks

The product names and company names used in this manual are the registered trademarks of the individual companies.

## Copyright

This manual is copyrighted with all rights reserved. Under the copyright laws, this manual may not be copied, reproduced or translated into another language, in whole or in part, without the written consent of Canon Inc.

***COPYRIGHT © 2001 CANON INC.***

*Printed in Japan*

## Caution









Use of this manual should be strictly supervised to avoid disclosure of confidential information.

---

## Symbols Used



---

This documentation uses the following symbols to indicate special information:

Symbol	Description
	Indicates an item of a non-specific nature, possibly classified as Note, Caution, or Warning.
	Indicates an item requiring care to avoid electric shocks.
	Indicates an item requiring care to avoid combustion (fire).
	Indicates an item prohibiting disassembly to avoid electric shocks or problems.
	Indicates an item requiring disconnection of the power plug from the electric outlet.
 Memo	Indicates an item intended to provide notes assisting the understanding of the topic in question.
 REF.	Indicates an item of reference assisting the understanding of the topic in question.
	Provides a description of a service mode.
	Provides a description of the nature of an error indication.

The following rules apply throughout this Service Manual:

1. Each chapter contains sections explaining the purpose of specific functions and the relationship between electrical and mechanical systems with reference to the timing of operation.

In the diagrams,  represents the path of mechanical drive; where a signal name accompanies the symbol, the arrow  indicates the direction of the electric signal.

The expression "turn on the power" means flipping on the power switch, closing the front door, and closing the delivery unit door, which results in supplying the machine with power.

2. In the digital circuits, '1' is used to indicate that the voltage level of a given signal is "High", while '0' is used to indicate "Low". (The voltage value, however, differs from circuit to circuit.) In addition, the asterisk (\*) as in "DRMD\*" indicates that the DRMD signal goes on when '0'.

In practically all cases, the internal mechanisms of a microprocessor cannot be checked in the field. Therefore, the operations of the microprocessors used in the machines are not discussed: they are explained in terms of from sensors to the input of the DC controller PCB and from the output of the DC controller PCB to the loads.

The descriptions in this Service Manual are subject to change without notice for product improvement or other purposes, and major changes will be communicated in the form of Service Information bulletins.

All service persons are expected to have a good understanding of the contents of this Service Manual and all relevant Service Information bulletins and be able to identify and isolate faults in the machine."



# Contents

## Chapter 1 Specifications

1.1 Product Specifications .....	1- 1
1.1.1 Specifications .....	1- 1
1.2 Names of Parts.....	1- 3
1.2.1 External View .....	1- 3
1.2.2 Cross Section .....	1- 3
1.3 Using the Machine.....	1- 5
1.3.1 Original Placement Indicator.....	1- 5
1.3.2 Warning and Action .....	1- 5

## Chapter 2 Functions

2.1 Basic Construction .....	2- 1
2.1.1 Overview of the Electrical Circuitry .....	2- 1
2.1.2 Inputs to the ADF Controller PCB .....	2- 1
2.1.3 Outputs from the ADF Controller PCB.....	2- 2
2.2 Basic Operation .....	2- 4
2.2.1 Route of Drive .....	2- 4
2.2.2 Overview of Operation Mode.....	2- 4
2.2.3 Clockwise Pickup/Delivery (single-sided original -> single-sided print) .....	2- 5
2.2.4 Clockwise Pickup/Reversal Deliver (double-sided original -> double-sided print) .....	2- 6
2.2.5 Idle Circulation/Pickup/Delivery (size-mix double-sided original -> double-side print) .....	2- 8
2.2.6 Idle Circulation/Reversal Pickup/Delivery (size-mix single-sided original -> single-sided print).....	2- 11
2.3 Document Detection .....	2- 14
2.3.1 Overview .....	2- 14
2.3.2 Checking the Presence/Absence of an Original .....	2- 15
2.3.3 Detecting the Last Original .....	2- 15
2.3.4 Initial Original Size Detection (feed direction).....	2- 16
2.3.5 Initial Original Size Detection (cross feed direction).....	2- 16
2.3.6 Slide Guide Positioning Roll .....	2- 18
2.3.7 Last Original Size Detection .....	2- 19
2.4 Document Pickup/Separation .....	2- 22
2.4.1 Basic Sequence of Operation .....	2- 22
2.4.2 Pickup Unit and the Stopper.....	2- 23
2.4.3 Timing of Pickup.....	2- 24
2.4.4 Controlling the Pickup Motor (M2) .....	2- 24
2.5 Document Reversing .....	2- 26
2.5.1 Basic Sequence of Operation .....	2- 26
2.5.2 Sequence of Operation .....	2- 27
2.6 Document Feeding/Delivery .....	2- 28
2.6.1 Basic Sequence of Operation .....	2- 28
2.6.2 Sequence of Operation .....	2- 29
2.6.3 Controlling the Feed Motor (M1).....	2- 29

2.7 Detecting Jams .....	2- 31
2.7.1 Jams .....	2- 31
2.8 Power Supply .....	2- 32
2.8.1 Power Supply .....	2- 32

### Chapter 3 Installation

3.1 Unpacking and Installation .....	3- 1
3.1.1 Unpacking and Chacking the Components .....	3- 1
3.1.2 Installation Procedure .....	3- 1
3.1.3 Making Adjustments .....	3- 3
3.1.4 Ataching the Labels etc. ....	3- 8
3.1.5 Checking the Operation .....	3- 9

### Chapter 4 Parts Replacement Procedure

4.1 Removing from the Host Machine .....	4- 1
4.1.1 Feeder .....	4- 1
4.2 Drive System .....	4- 2
4.2.1 Pickup Motor .....	4- 2
4.2.2 Feed Motor .....	4- 3
4.2.3 Timing Belt/Pulley .....	4- 5
4.3 Document Feeding System .....	4- 9
4.3.1 Pickup Roller Unit .....	4- 9
4.3.2 Pickup Roller/Separation Roller .....	4- 10
4.3.3 Separation Plate/Separation Pad .....	4- 11
4.3.4 Upper Registration Roller .....	4- 12
4.3.5 Lower Registration Roller .....	4- 13
4.3.6 Delivery Reversing Roller (upper) .....	4- 20
4.3.7 Read Roller 1 .....	4- 24
4.3.8 Read Roller 2 .....	4- 30
4.3.9 Platen Roller .....	4- 34
4.3.10 Delivery Reversing Roller (lower) .....	4- 39
4.3.11 Read Roller Roll .....	4- 43
4.3.12 Separation Guide Sheet .....	4- 44
4.3.13 Feed Roller Guide .....	4- 45
4.4 Electrical System .....	4- 46
4.4.1 ADF Controller PCB .....	4- 46
4.4.2 Inner Sensor of Feed Unit .....	4- 46
4.4.3 Document Width Volume .....	4- 53
4.4.4 ADF Open/Closed Sensor .....	4- 54
4.4.5 Cover Open/Closed Sensor .....	4- 55
4.4.6 Document Set Sensor .....	4- 56
4.4.7 Pressurization Solenoid .....	4- 56

### Chapter 5 Maintenance

5.1 User Maintenance .....	5- 1
5.1.1 Cleaning .....	5- 1



5.1.2 Replacement .....	5- 2
5.2 Maintenance and Inspection .....	5- 3
5.2.1 Periodically Replaced Parts .....	5- 3
5.2.2 Durables .....	5- 3
5.2.3 Periodical Servicing .....	5- 3
5.2.4 Cleaning .....	5- 6
5.3 Adjustment .....	5- 11
5.3.1 Basic Adjustment .....	5- 11
5.3.2 Adjustment at Time of Parts Replacement .....	5- 18
5.4 Outline of Electrical Components .....	5- 20
5.4.1 sensors .....	5- 20
5.4.2 Motors, Clutches, Solenoids, PCBs, and Others .....	5- 21
5.5 Variable Resistors (VR), Light-Emitting Diodes (LED), and Check Pins by PCB .....	5- 22
5.5.1 Overview .....	5- 22
5.5.2 ADF Controller PCB .....	5- 22
5.5.3 Relay PCB .....	5- 22
5.5.4 Original Placement LED PCB .....	5- 23

## Chapter 6 Error Code

6.1 Overview .....	6- 1
6.1.1 Overview .....	6- 1
6.2 User Error Code .....	6- 2
6.2.1 Alarm .....	6- 2



---

# Chapter 1 Specifications

---



# Contents

1.1 Product Specifications .....	1-1
1.1.1 Specifications .....	1-1
1.2 Names of Parts.....	1-3
1.2.1 External View.....	1-3
1.2.2 Cross Section .....	1-3
1.3 Using the Machine.....	1-5
1.3.1 Original Placement Indicator.....	1-5
1.3.2 Warning and Action .....	1-5



# 1.1 Product Specifications

## 1.1.1 Specifications

0001-9119

T-1-1

Item	Description	Remarks
Original pickup method	auto pickup/delivery	
Original orientation	original tray: face-up	
Original placement	original tray: center reference	
Original separation method	top separation	
Original type	single-sided sheet:	if longer than 432 mm in length, 60 to 90 g/m <sup>2</sup> ; single feed
	AB-configuration: 42 to 128 g/m <sup>2</sup>	
	Inch-configuration: 50 to 128 g/m <sup>2</sup>	
	double-sided original: 50 to 128 g/m <sup>2</sup>	
	colored original: 64 to 128 g/m <sup>2</sup>	
	black-and-white/color mix: 50 to 128 g/m <sup>2</sup>	
Original size	AB-configuration: B6/A5/B5/A4/A5R/A4R/B4/A3	if STMT/B6, horizontal feed only
	Inch-configuration: STMT/LTR/LTRR/LGL/11"×17"	
	original width: 148 to 297 mm	
	original length (feed direction): 128 to 432 (630) mm	value in (()) is supported by operator
Stack on original tray	50 sheets	paper of 80 g/m <sup>2</sup>
Stack on original delivery assembly	50 sheets	paper of 80 g/m <sup>2</sup>
Original processing mode	single-sided original processing	
Original size identification	yes (default size only)	

Item		Description	Remarks
Original size mix		yes, of same configuration	
		yes, of different configurations	
		combination of different paper configurations	
		AB-configuration: A3/B4 A4/B5 B4/A4R B5/A5 A5/B6	
Book original		supported (50 mm or less in thickness)	
Original processing speed		single-sided: 28 ipm	for A4/LTR
		double-sided: 13 ipm	
Communication with host machine		serial	
Power supply		DC24V POWER DC13V LOGIC	from host machine
Weight		8.5 kg (approx.)	
Dimensions		565 (W) x 538 (D) x 122 (H) mm	
Serial No.		A-model	JESxxxxx
		Inch/A-model	JERxxxxx
		AB-model	JEQxxxxx
		Inch/AB-model	JEUxxxxx
Operating environment	temperature range	same as host machine	
	humidity range	same as host machine	



## 1.2 Names of Parts

### 1.2.1 External View

0000-9992

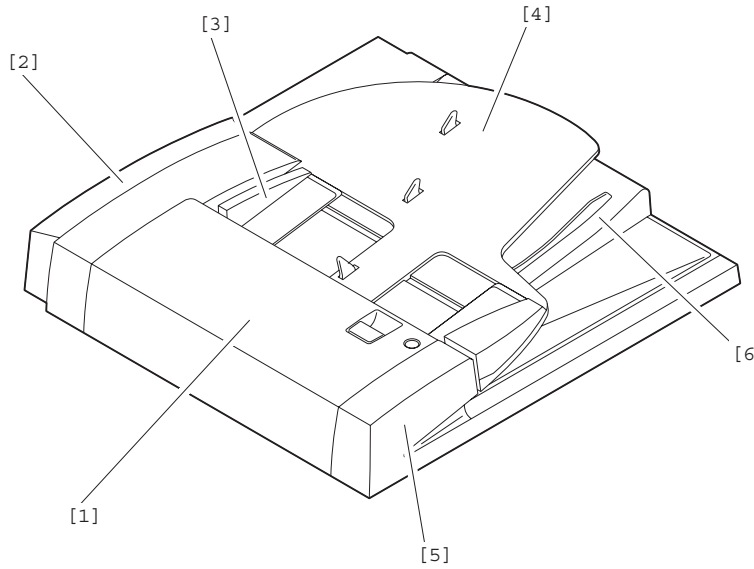

F-1-1

T-1-2

[1] Feeder cover

[4] Original pickup tray

[2] Rear cover

[5] Front cover

[3] Slide guide

[6] Original delivery assembly

### 1.2.2 Cross Section

0001-0004

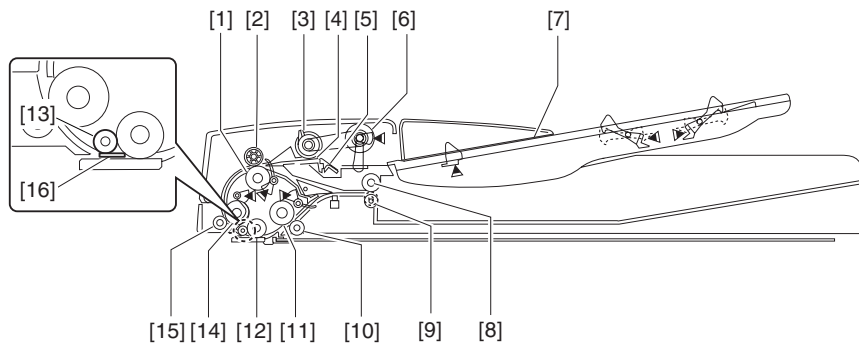

F-1-2

- [1] Lower registration roller
- [2] Upper registration roller
- [3] Separation roller
- [4] Separation pad
- [5] Separation plate
- [6] Pickup roller
- [7] Original pickup tray
- [8] Upper delivery reversing roller
- [9] Lower delivery reversing roller
- [10] Read roller 2 roll
- [11] Read roller 2
- [12] Platen roller
- [13] Read roll
- [14] Read roller 1 roll
- [15] Read roller 1
- [16] White sheet

---

## 1.3 Using the Machine

---

### 1.3.1 Original Placement Indicator

0001-0022

The original placement indicator goes on in response to the placement of an original in the original tray; it starts to flash in response upon detection of an original jam.

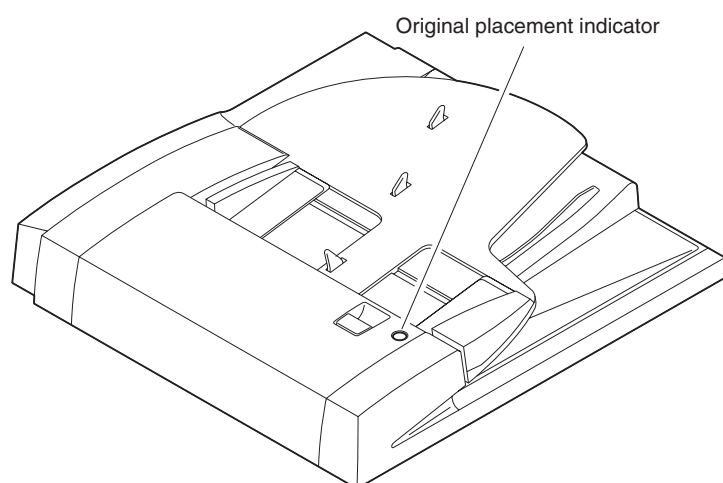

F-1-3

### 1.3.2 Warning and Action

0001-0026

If the original placement indicator starts to flash while an original is being moved, suspect a jam, and correct the fault by going through the following:

- 1) Remove all originals from the original tray.
- 2) Open the feeder cover, and remove any jam.
- 3) Put the originals back and in sequence together, and place the stack in the ADF once again.



---

# Chapter 2    Functions

---



---

---

# Contents

2.1 Basic Construction .....	2-1
2.1.1 Overview of the Electrical Circuitry .....	2-1
2.1.2 Inputs to the ADF Controller PCB .....	2-1
2.1.3 Outputs from the ADF Controller PCB .....	2-2
2.2 Basic Operation .....	2-4
2.2.1 Route of Drive .....	2-4
2.2.2 Overview of Operation Mode .....	2-4
2.2.3 Clockwise Pickup/Delivery (single-sided original -> single-sided print) .....	2-5
2.2.4 Clockwise Pickup/Reversal Deliver (double-sided original -> double-sided print) .....	2-6
2.2.5 Idle Circulation/Pickup/Delivery (size-mix double-sided original -> double-side print) .....	2-8
2.2.6 Idle Circulation/Reversal Pickup/Delivery (size-mix single-sided original -> single-sided print) .....	2-11
2.3 Document Detection .....	2-14
2.3.1 Overview .....	2-14
2.3.2 Checking the Presence/Absence of an Original .....	2-15
2.3.3 Detecting the Last Original .....	2-15
2.3.4 Initial Original Size Detection (feed direction) .....	2-16
2.3.5 Initial Original Size Detection (cross feed direction) .....	2-16
2.3.6 Slide Guide Positioning Roll .....	2-18
2.3.7 Last Original Size Detection .....	2-19
2.4 Document Pickup/Separation .....	2-22
2.4.1 Basic Sequence of Operation .....	2-22
2.4.2 Pickup Unit and the Stopper .....	2-23
2.4.3 Timing of Pickup .....	2-24
2.4.4 Controlling the Pickup Motor (M2) .....	2-24
2.5 Document Reversing .....	2-26
2.5.1 Basic Sequence of Operation .....	2-26
2.5.2 Sequence of Operation .....	2-27
2.6 Document Feeding/Delivery .....	2-28
2.6.1 Basic Sequence of Operation .....	2-28
2.6.2 Sequence of Operation .....	2-29
2.6.3 Controlling the Feed Motor (M1) .....	2-29
2.7 Detecting Jams .....	2-31
2.7.1 Jams .....	2-31
2.8 Power Supply .....	2-32
2.8.1 Power Supply .....	2-32





## 2.1 Basic Construction

### 2.1.1 Overview of the Electrical Circuitry

0001-0068

The electrical mechanisms of the machine are controlled by the reader controller PCB. The CPU of the reader unit interprets input signals and the signals from the host machine, and generates signals used to drive such DC loads as motors and solenoids. The ADF controller PCB does not have a memory area, and the EEPROM of the reader controller PCB is used to store such data as service mode settings.

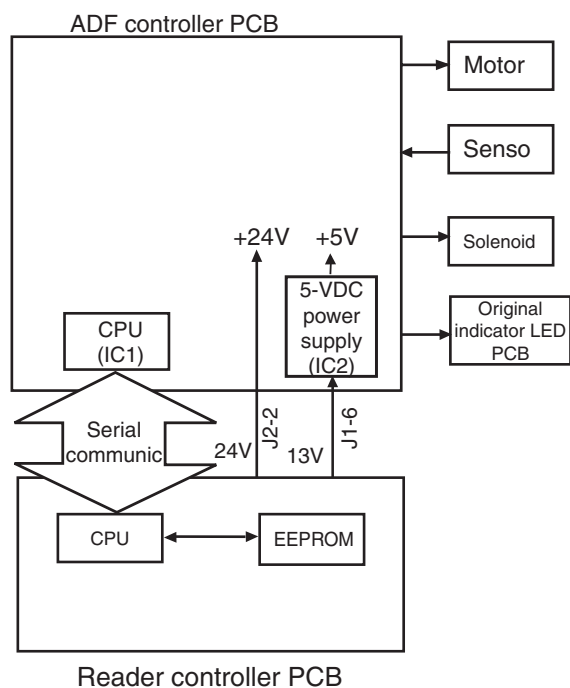

F-2-1

### 2.1.2 Inputs to the ADF Controller PCB

0001-0106

Inputs to the ADF Controller PCB (1/1)



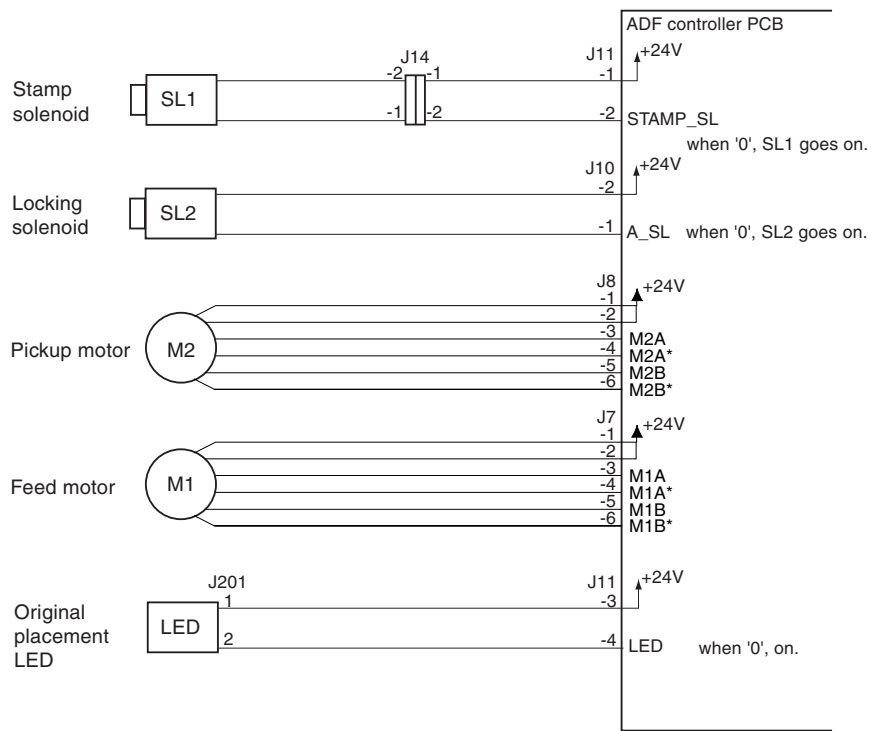

F-2-3

## 2.2 Basic Operation

### 2.2.1 Route of Drive

0001-0111

The machine is a document feeder exclusively designed for stream reading. It uses 2 motors for picking up and moving originals.

T-2-1

Name (notation)	Description
Feed motor (M1)	moves originals.
Pickup motor (M2)	separates/moves originals.

The following is a diagram showing the route of drive used in the machine:

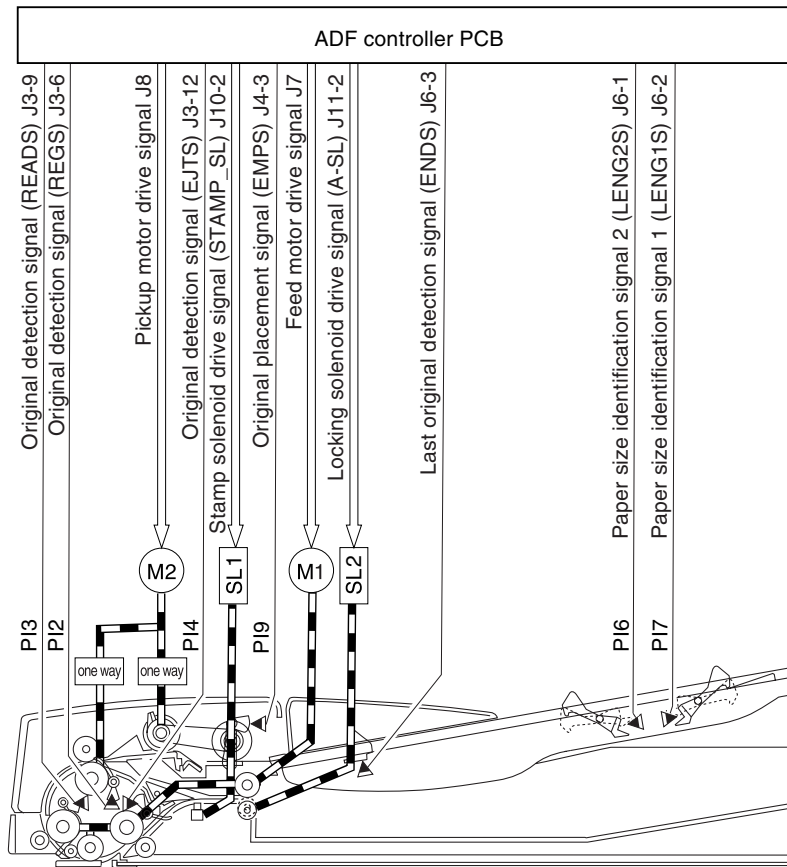

F-2-4

### 2.2.2 Overview of Operation Mode

0001-0117

The machine operates in any of the following 4 operating modes, used in keeping with the instructions from the

machine to execute print jobs; these modes may be characterized as follows:

## T-2-2

Operating mode	Operation	Corresponding print mode
[1] clockwise pickup/ delivery	picks up an original, reads it, and delivers it.	single-sided original -> single-sided print single-sided original -> double-sided print
[2] clockwise pickup/ reversal delivery	picks up an original, reads it, turns it over, and delivers it.	double-sided original -> double-sided print double-sided original -> single-sided print
[3] idle circulation/ reversal pickup/reversal delivery	circulates an original idly to identify its size; then, circulates the original idly for starting with its face; finally, picks up the original, reads it, turns it over, and delivers it.	size-mix double-sided original -> double-sided print size-mix double-sided original -> single-side print
[4] idle circulation/ reversal pickup/delivery	circulates an original idly to identify its size; then, turns it over, reads it, and delivers it.	size-mix single-sided original -> single-side print size-mix single-sided original -> double-sided print

An original may be of small-size or large-size as shown:

## T-2-3

Small-size	B6, A5R, A5, A4, B5, LTR, STMT
Large-size	A4R, B5R, A3, B4, LTRR, LGL, 11"×17"

### 2.2.3 Clockwise Pickup/Delivery (single-sided original -> single-sided print)

0001-0169

The following shows the flow of an original:

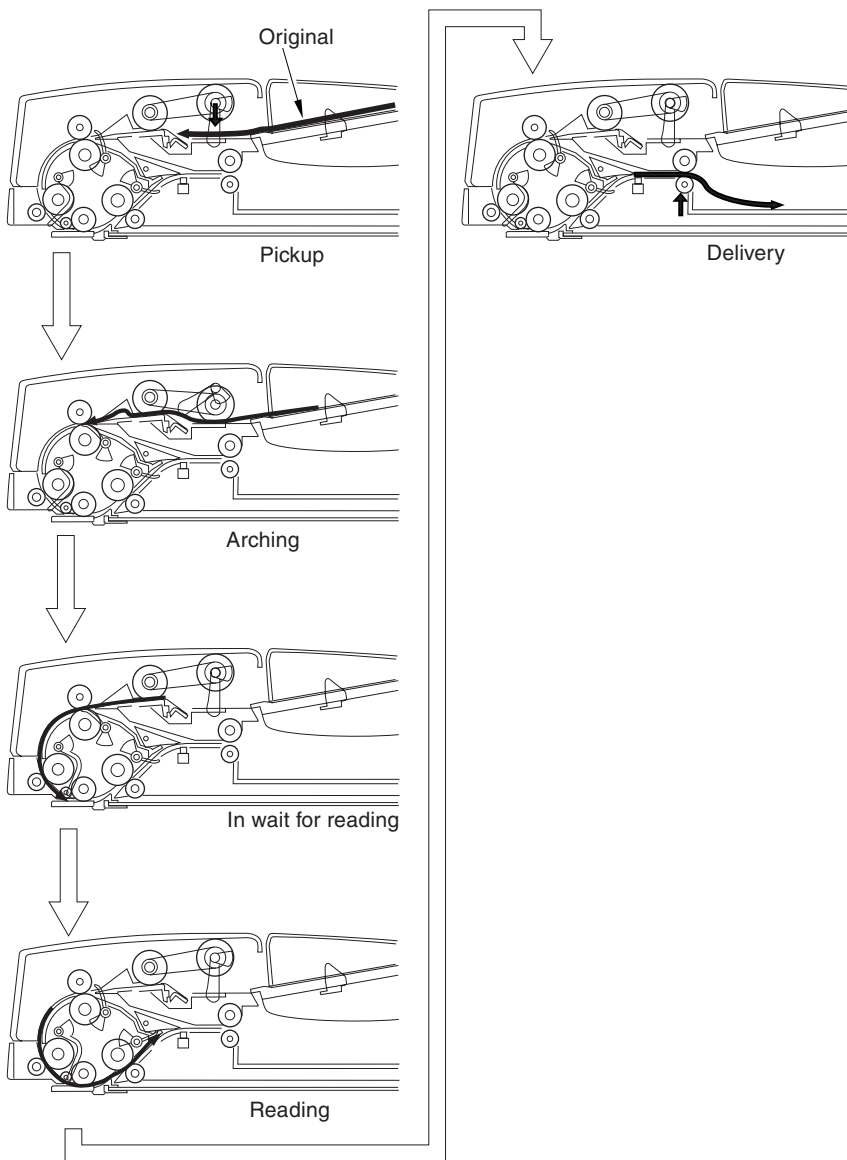

F-2-5

## 2.2.4 Clockwise Pickup/Reversal Deliver (double-sided original -> double-sided print)

0001-0179

The following shows the flow of an original:

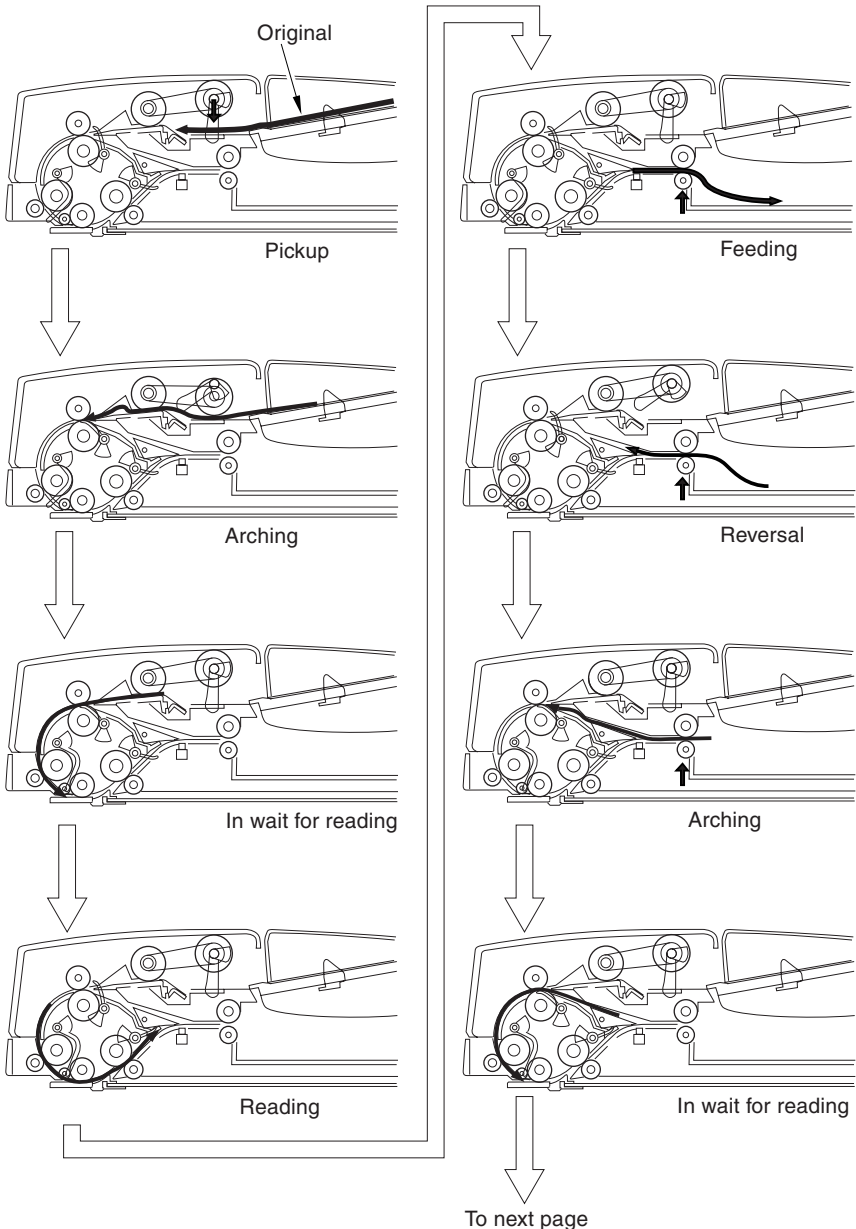

F-2-6

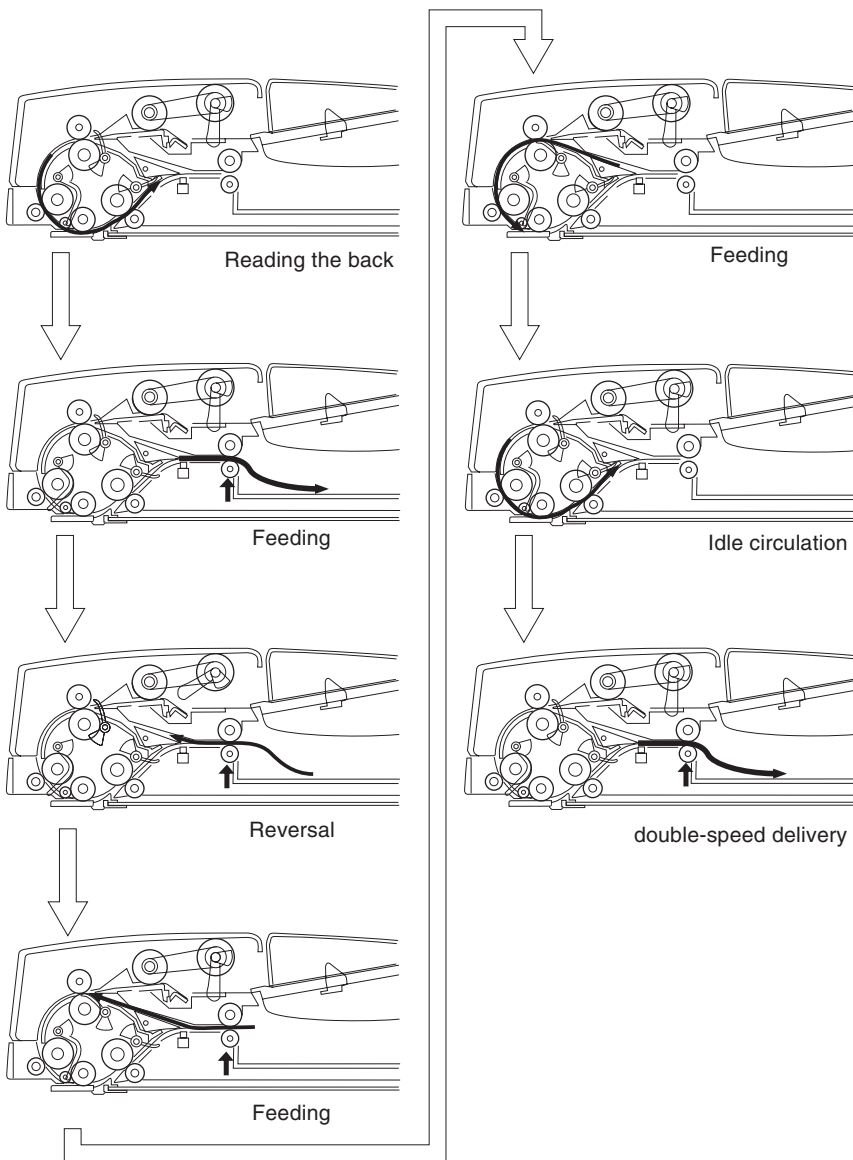

F-2-7

### 2.2.5 Idle Circulation/Pickup/Delivery (size-mix double-sided original - > double-side print)

0001-0182

The following shows the flow of an original:



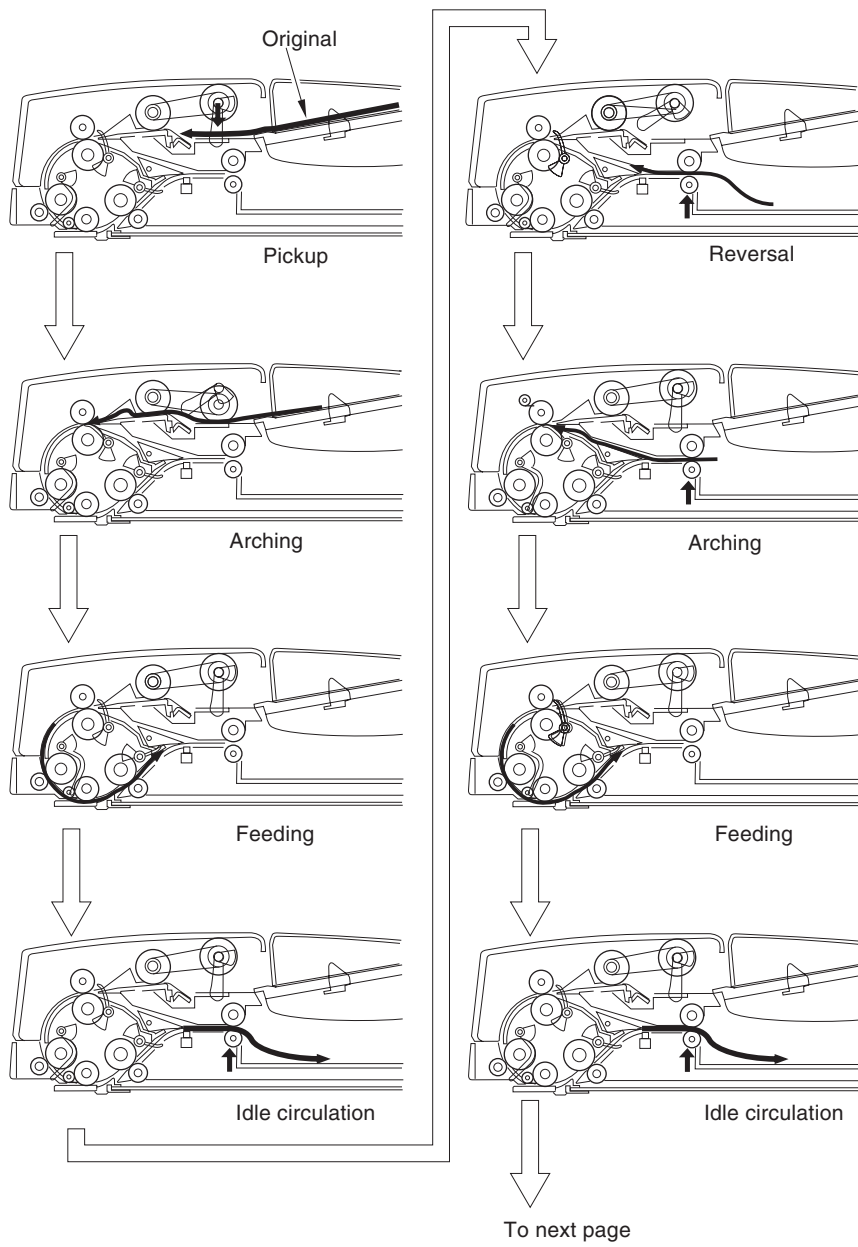

F-2-8

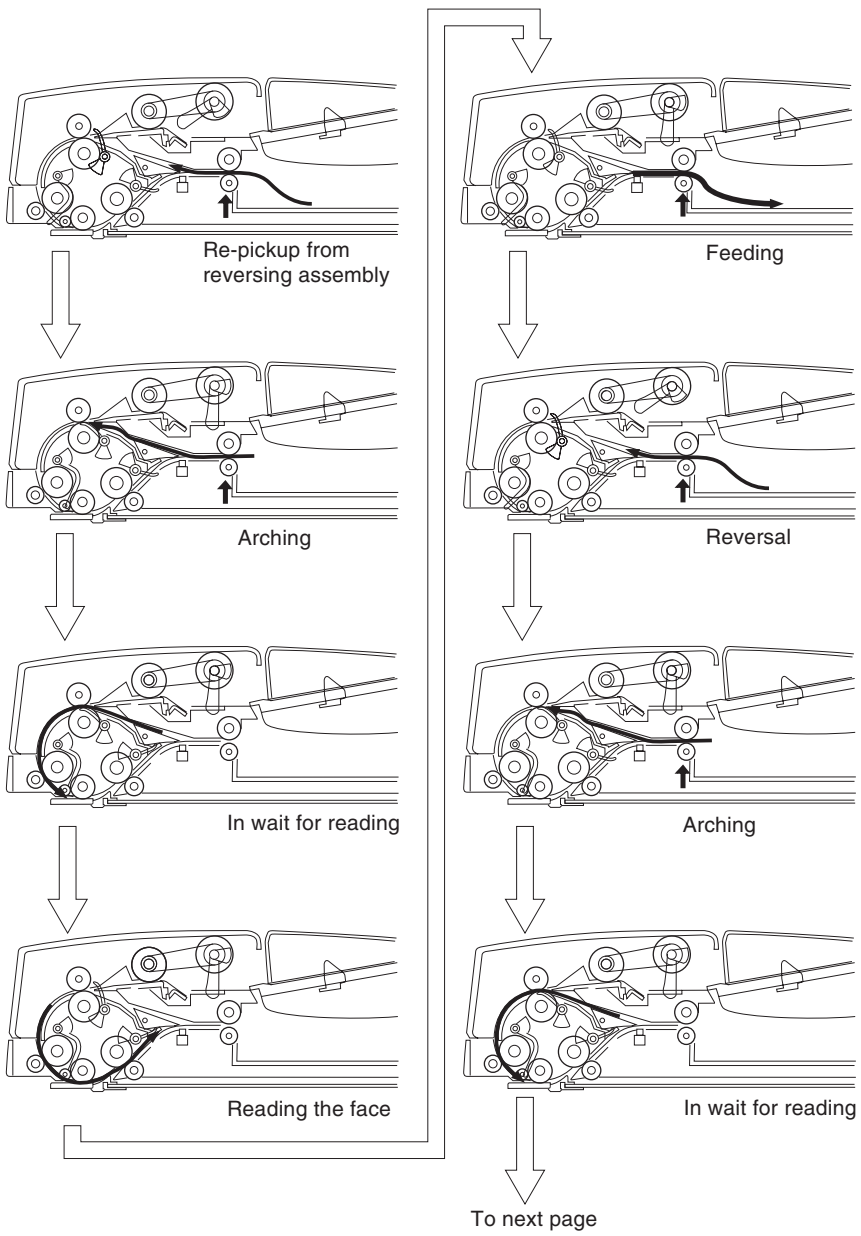

F-2-9

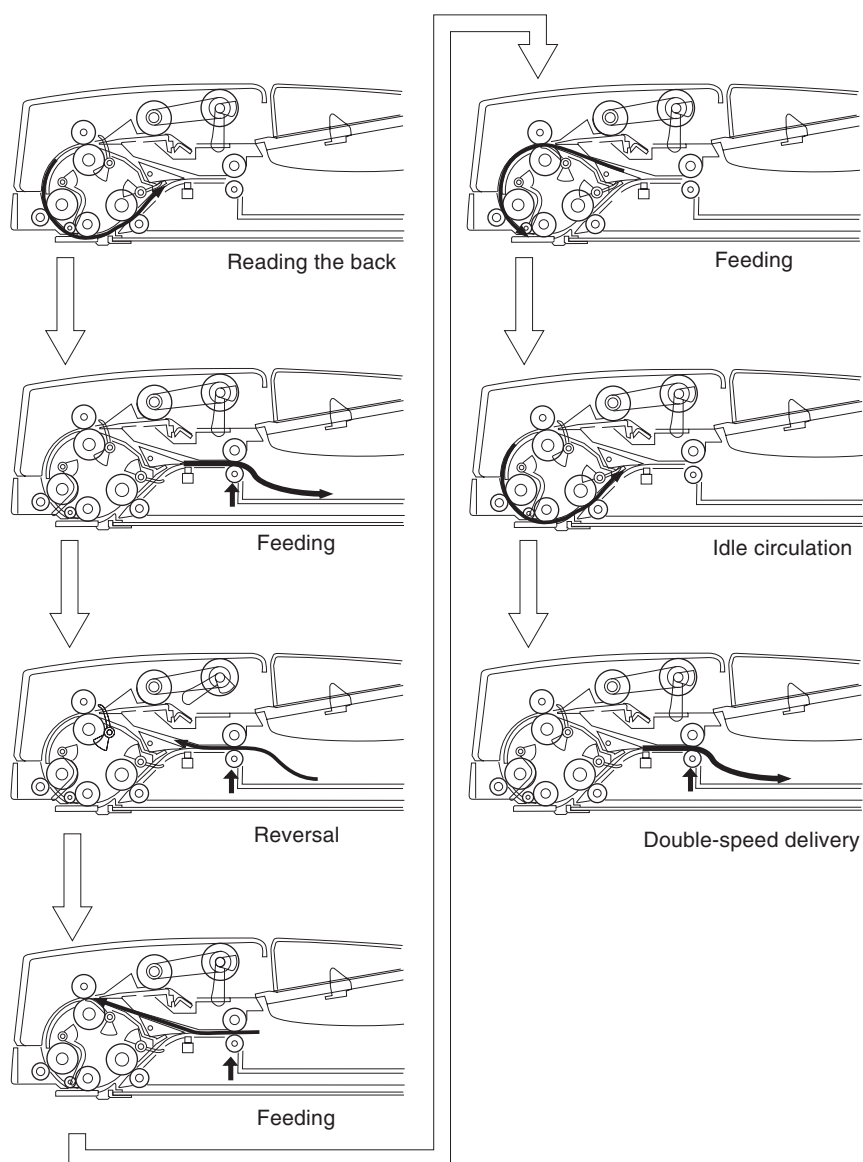

F-2-10

## 2.2.6 Idle Circulation/Reversal Pickup/Delivery (size-mix single-sided original -> single-sided print)

0001-0191

The following shows the flow of an original:

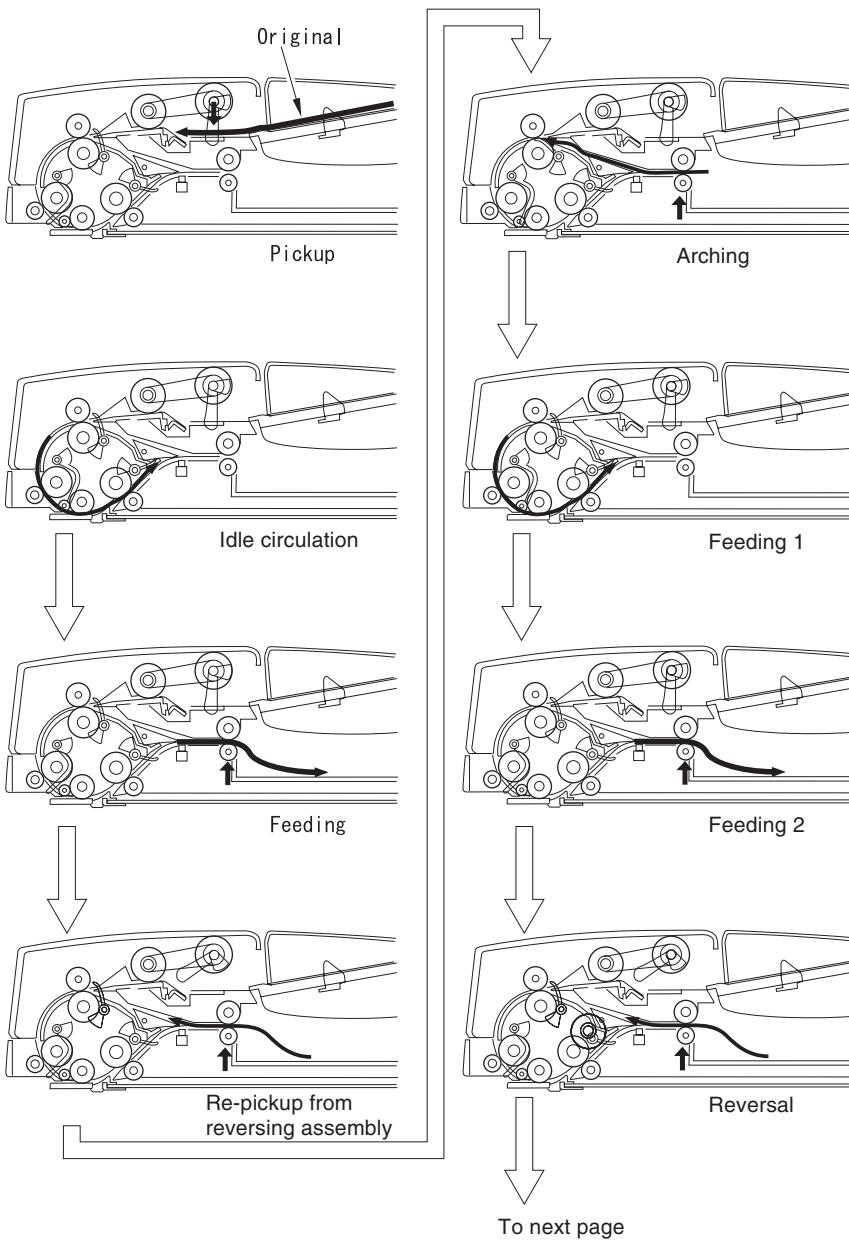

F-2-11

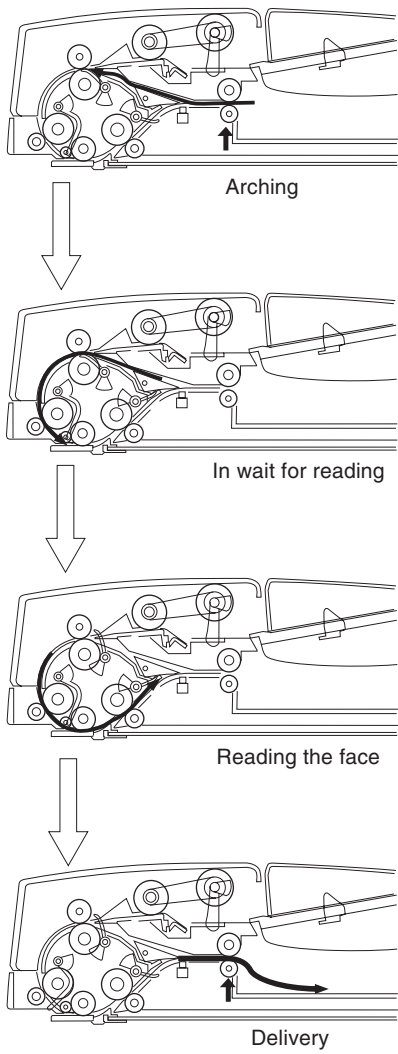

F-2-12

## 2.3 Document Detection

### 2.3.1 Overview

0001-0196

The machine's original detection mechanisms go on for either of the following:

- normal printing (other than size-mix print and extra-length paper mode)
- configuration-mix print, extra-length paper mode

#### a. Normal Print (other than size-mix print and extra-length paper mode)

For a normal print job, the following 4 original detection mechanisms are used:

#### T-2-4

Item	Description	Sensor used (notation)
Original detection	Checks the presence/absence of an original on the original pickup tray.	Original placement sensor (PI9)
Last original detection	Checks to see if the original being moved is the last original.	Last original sensor (PI8)
Initial original size detection		
- feed direction	Checks the length of the original placed on the original pickup tray; small-size or large size and LTRR or LGL	Length sensor 1/2 (PI7/PI6)
- cross-feed direction	Checks the width of the original placed on the original pickup tray.	Original width volume (VR1) A4R/LTRR identification sensor (I5)

#### b. Size-Mix Print/Extra-Length Paper Mode

When in configuration-mix print, the following 3 original detection mechanisms are used:

#### T-2-5

Item	Description	Sensor used (notation)
Original detection	checks the presence/absence of an original on the original pickup tray.	original placement sensor (PI9)

Item	Description	Sensor used (notation)
Last original detection	checks to see if the original being moved is the last original.	last original sensor (PI8)
Original length detection	identifies the length of the original with reference to the length of feed made between the activation and the deactivation of the read sensor (PI7); it also uses the width of the original for distinction between A5R and A4.	read sensor (PI3) original width volume (VR1)

### 2.3.2 Checking the Presence/Absence of an Original

0001-0239

The machine uses the original placement sensor (PI9) to check the presence/absence of an original on the original tray. When an original is placed on the original tray, the detecting lever operates in conjunction with the light-blocking plate, permitting light to pass through the photo-interrupter, causing the original placement sensor (PI9) to generate the original detection signal (EMPS); in response, the ADF controller PCB causes the original placement indicator to go on.

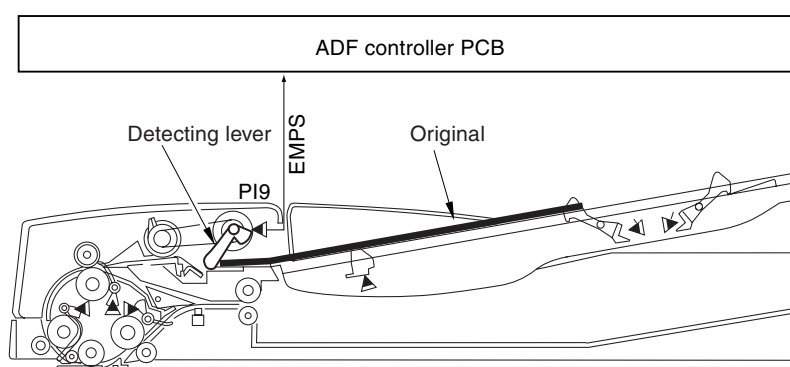

F-2-13

### 2.3.3 Detecting the Last Original

0001-0240

The machine uses the last original sensor (PI8) and the original placement sensor (PI9) to see if the original being picked is the last original from the stack placed on the original tray.

When the last original is picked up and its trailing edge moves past the last original detecting lever of the original tray, the detection lever operates in conjunction with the light-blocking plate to permit light through the photo-interrupter. As a result, the last original sensor (PI8) generates the last original detection signal (ENDS); when the last original moves past the original sensor (PI9), the sensor generates the original absent signal (EMPS) to communicate to the host machine that the original being picked up is the last original.

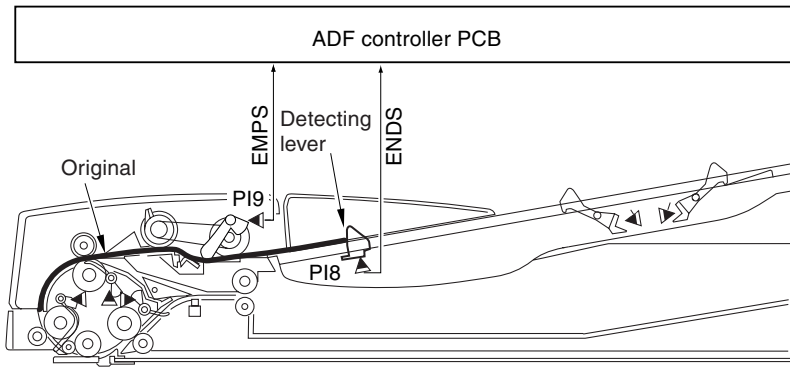

F-2-14

### 2.3.4 Initial Original Size Detection (feed direction)

0001-0242

The initial original size detection (feed direction) mechanism consists in the identification of the length of the original placed on the original tray by the length sensor 1 (PI7) and the length sensor 2 (PI6).

When an original is placed on the original tray, the detecting levers of the 2 length sensors operate in conjunction with the light-blocking plate, which blocks the photo interrupter. The combination of the signals (LENG1S/LENG2S) of these 2 length sensors and the identified width (discussed later) are used to identify the size of the original for communication to the host machine. When the Start key is pressed, the original size is checked and communicated to the host machine in real time

The following shows an outline of the relationship between the individual length sensor signals and original widths as they relate to the original size detection mechanisms:

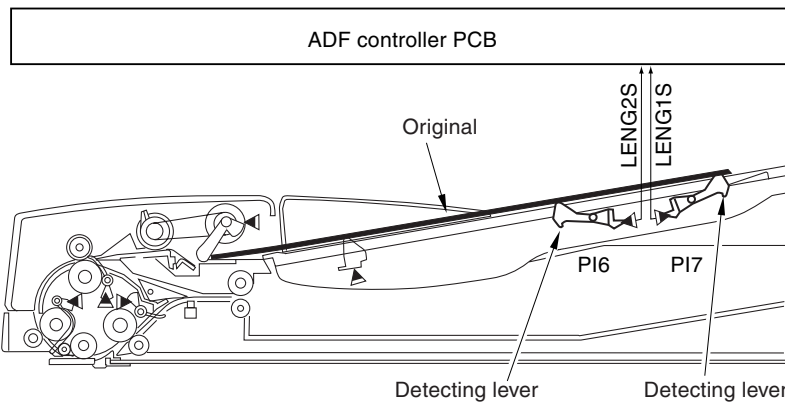

F-2-15

### 2.3.5 Initial Original Size Detection (cross feed direction)

0001-0245

The machine uses the original width volume (VR1) found inside the original tray to perform initial original size detection (cross feed direction). The original width detection volume operates in conjunction with the slide guide, and the movement of the guide changes the resistance of the volume (analog). The ADF controller checks the changes in the resistance through the original size signal (VR) to identify the length of the original in cross feed



direction.

So that the original width volume (VR1) may accurately check the width (A4R, 210 mm; LTRR, 216 mm), the machine has separate sensors (A4R/LTRR identification sensor, P15) inside the original tray; the sensor causes the A4R/LTRR identification signal to go '1' when the paper in question is 197 mm or longer but shorter than 214 mm.

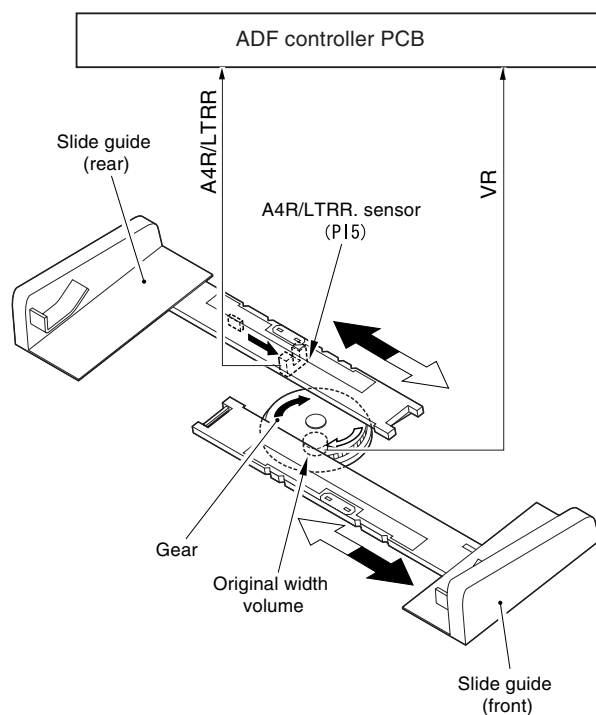

F-2-16

The following shows the relationship between the individual length sensor signals and the results of initial original size detection:

T-2-6

Original width w (mm)	A4/ LTRR*1 identified sensor	Result of detection				
		Tray sensor 2	Tray sensor 1	Mix	AB	Inch
w ≤ 171	-	OFF	OFF	A5R	A5R	STMT
		ON	OFF	B5R	B5R	
		-	ON	B4	B4	LGL
172 ≤ w ≤ 199	-	OFF	OFF	B6	B6	STMT
		ON	OFF	B5R	B5R	LTRR
		-	ON	B4	B4	LGL

Original width w (mm)  (width detecting VR)	A44/ LTRR*1 identified sensor	Result of detection				
		Tray sensor 2	Tray sensor 1	Mix	AB	Inch
200<=w<=246	ON	OFF	OFF	A5	A5	STMT
		ON	OFF	A4R	A4R	LTRR
		-	ON	B4	B4	LGL
	OFF	OFF	OFF	STMT	A5	STMT
		ON	OFF	LTRR	A4R	LTRR
		-	ON	LGL	B4	LGL
247<=w<=271	-	OFF	OFF	B5	B5	LTR
		ON	-	B4	B4	11"×17"
		-	ON	B4	B4	11"×17"
272<=w<=288	-	OFF	OFF	LTR	A4	LTR
		ON	-	11"×17"	A3	11"×17"
		-	ON	11"×17"	A3	11"×17"
289<=w<=297	-	OFF	OFF	A4	A4	LTR
		ON	-	A3	A3	11"×17"
		-	ON	A3	A3	11"×17"

\*1: however, the A4R/LTRR identification sensor goes on when the paper is 197 mm or longer but shorter than 214 mm.

### 2.3.6 Slide Guide Positioning Roll

0001-0317

The rail of the slide guide is given a groove so that it may stop at specific default size positions. Some paper sizes, however, are located appreciably near each other, possibly stopping the guide at the wrong position.

The slide guide positioning roll (2 types) is offered so as to enable changing the stop position of the slide guide, making sure that it stops at exact default positions as shown:

## T-2-7

Slide guide Positioning roll color and marking	Slide guide stop position	
	Side with 1 groove	Side with 2 grooves
white/A and marking (for A/B)	A4R	A4R LTRR
black/L and marking (for Inch)	LTRR	A4R LTRR

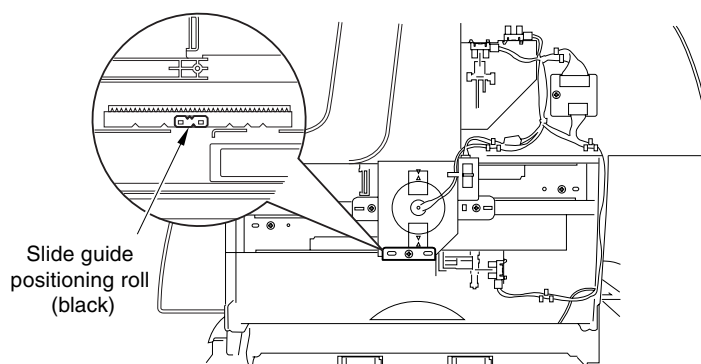

F-2-17

### 2.3.7 Last Original Size Detection

0001-0327

The machine detects the size of any last original in terms of the length of the original and the result of initial original size detection: for the former, it uses the drive of the feed motor used to move the paper past the read sensor (PI3); for the latter, it uses the original width volume (VR1).

When an original moves past the detecting lever of the read sensor (PI3), the detecting lever operates in conjunction with the light-blocking plate to block the photo-interrupter. The machine uses the length of feed with reference to the number of clock pulses from the feed motor (M1) generated from when the read sensor (PI3) goes on until when the sensor goes off. The read sensor (I3) generates the last original detection signal (ENDS) for the ADF controller PCB.

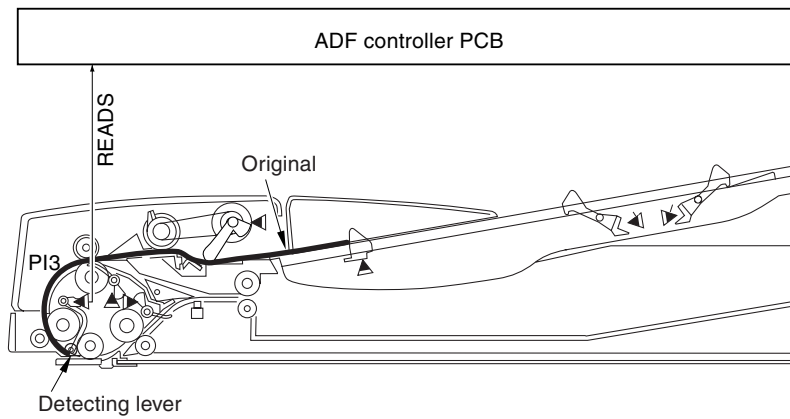

F-2-18

The following shows the default sizes the machine identifies based on these mechanisms:

AB Configuration-Mix Mode

T-2-8

Default size	Original width w (mm)	Original length l (mm)
B6		$l \leq 138$
A5		$141 \leq l \leq 165$
B5		$166 \leq l \leq 196$
A5R	$w \leq 199$	$197 \leq l \leq 234$
A4	$w \leq 200$	$197 \leq l \leq 234$
B5R		$235 \leq l \leq 277$
A4R		$278 \leq l \leq 331$
B4		$332 \leq l \leq 392$
A3		$393 \leq l$

[Inch Configuration-Mix Mode]

## T-2-9

Default size	Original width w (mm)	Original length l (mm)
STMT		$l \leq 178$
LTR		$179 \leq l \leq 248$
LTRR		$249 \leq l \leq 318$
LGL		$319 \leq l \leq 394$
11"×17"		$395 \leq l$

[Default Size Other Than in Configuration-Mix Mode]

## T-2-10

Default side			Original width w (mm)	Original length l (mm)	A4R/LTRR identification sensor (PI2)
Mix	AB	Inch			
A5R	A5R	STMT	$171 \leq w$	$l \leq 200$	
B5R	B5R	LYRR		$201 \leq l \leq 300$	
B4	B4	LGL		$301 \leq l$	
B6	B6	STMT	$172 \leq w \leq 199$	$l \leq 200$	
B5R	B5R	LTRR		$201 \leq l \leq 300$	
B4	B4	LGL		$301 \leq l$	
STMT	A5	STMT	$200 \leq w \leq 246$	$l \leq 200$	ON*1
LTRR	A4R	LTRR		$201 \leq l \leq 300$	
LGL	B4	LGL		$301 \leq l$	
A5	A5	STMT	$200 \leq w \leq 246$	$l \leq 200$	OFF
A4R	A4R	LTRR		$201 \leq l \leq 300$	
B4	B4	LGL		$301 \leq l$	
B5	B5	LTR	$247 \leq w \leq 268$	$l \leq 250$	
B4	B4	11"×17"		$251 \leq l$	
LTR	A4	LTR	$269 \leq w \leq 288$	$l \leq 350$	
11"×17"	A3	11"×17"		$351 \leq l$	
A4	A4	LTR	$w \leq 289$	$l \leq 350$	
A3	A3	11"×17"		$351 \leq l$	

\*1: the A4R/LTRR identification sensor (PI3) goes on when the original is 197 mm wide but narrower than 214 mm.

## 2.4 Document Pickup/Separation

### 2.4.1 Basic Sequence of Operation

0001-0390

When the Start key is pressed with originals placed in the tray, the machine executes the following sequence of operation:

#### a. Pickup

When the pickup motor (M2) rotates in reverse, the pickup roller unit moves down to rotate the pickup roller, thus moving an original. The stopper moves up in keeping with the movement of the pickup roller unit. The separation plate and the separation pad serve to prevent multiple feeding.

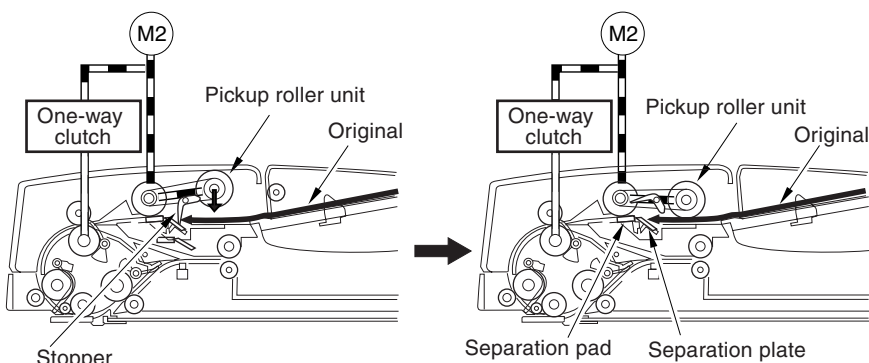

F-2-19

#### b. Arching

While the pickup motor (M2) is rotating in reverse, the idle rotation of the one-way clutch butts the paper against the registration roller, thus causing it to arch and removing its skew.

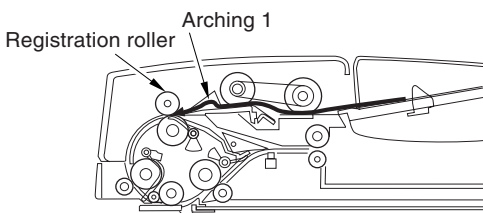

F-2-20

#### c. Feed

The pickup motor (M2) and the feed motor (M1) rotate in normal direction; as soon as the pickup roller unit moves up, the registration roller and the read roller move the original as far as the read standby position, stopping to rotate when the original reaches the position.

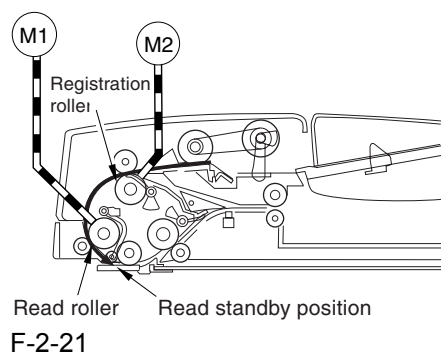

#### d. Stream Reading

When the leading edge of the original reaches the read position, the machine starts stream reading mode by sending the image leading edge signal to the host machine. In stream reading mode, the machine moves the original over the glass of the host machine for scanning. (The host machine's scanner is held in position.)

The image that has been read is stored in the host machine's memory.

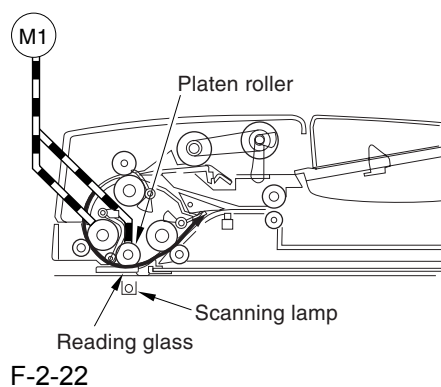

### 2.4.2 Pickup Unit and the Stopper

0001-0412

The pickup unit consists of a pickup roller and a separation roller. When the Start key is pressed or the original pickup signal arrives, the pickup motor (M2) rotates in reverse, causing the pickup roller to move down and the pickup roller and the separation roller to start to move paper. The stopper moves up in keeping with the movement of the pickup unit; the separation pad and the separation plate are used to prevent multiple feeding that otherwise may occur at time of pickup.

When the original reaches the registration roller and starts to arch, the pickup motor rotates in normal direction to move up the pickup unit, thus moving the original by the registration roller. All this while, the separation roller drive shaft driven by way of the spring one-way clutch remains at rest at the upper limit of the pickup roller; the separation roller rotates by the friction against paper and by the work of the one-way clutch.

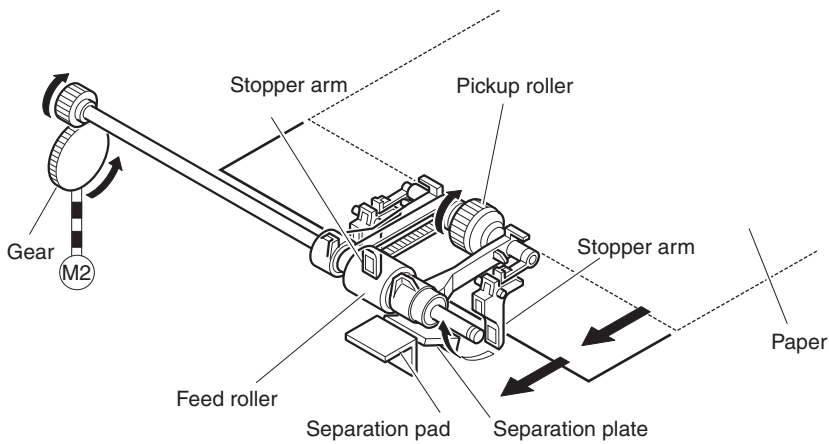

F-2-23

### 2.4.3 Timing of Pickup

0001-0413

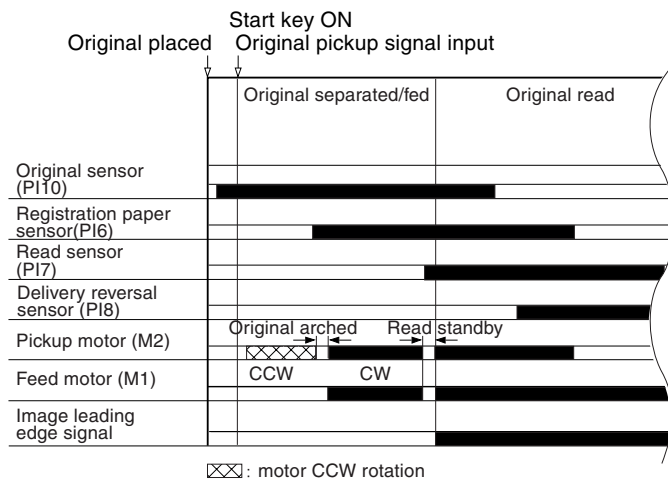

F-2-24

### 2.4.4 Controlling the Pickup Motor (M2)

0001-0415

The following is the circuit used to control the pickup motor (M2); the pickup motor is a 4-phase stepping motor, and the circuit is used of the following:

- turning on/off the motor
- controlling the direction of motor rotation
- controlling the speed of motor rotation



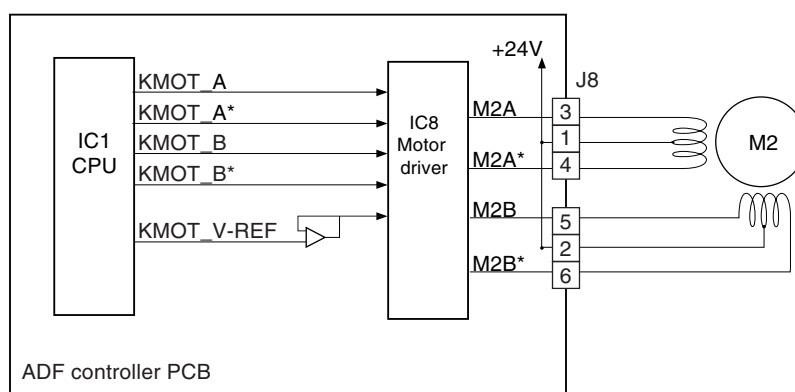

F-2-25

The CPU (IC1) on the ADF control PCB receives commands from the host machine for print mode (magnification, operating mode, timing, etc.). In response, it sends the appropriate drive pulses to the pickup motor.

The pickup motor is a stepping motor, and changes the direction and speed of its rotation as the order and the frequency of the drive pulses are changed (M2A, M2A\*; M2B, M2B\*).

T-2-11

Signal	Description
KMOT_A	drive pulse A
KMOT_A*	drive pulse A (reverse phase)
KMOT_B	drive pulse B
KMOT_B*	drive pulse B (reverse phase)
KMOT_V-REF	reference current setting

## 2.5 Document Reversing

### 2.5.1 Basic Sequence of Operation

0001-0416

The machine may turn an original from its 1st side to its 2nd side or from its 2nd side to its 1st side; the operation is the same, and the following discussions are based on reversal from the 1st side to the 2nd side.

#### a. Pickup for the 1s Side

The drive of the feed motor (M1) rotates the read roller and the platen roller for reading of the 1st side. As soon as reading ends (image leading edge signal going off), the locking solenoid (SL1) goes on so that the delivery reversing roller gets locked in place, causing the paper to move to the delivery assembly.

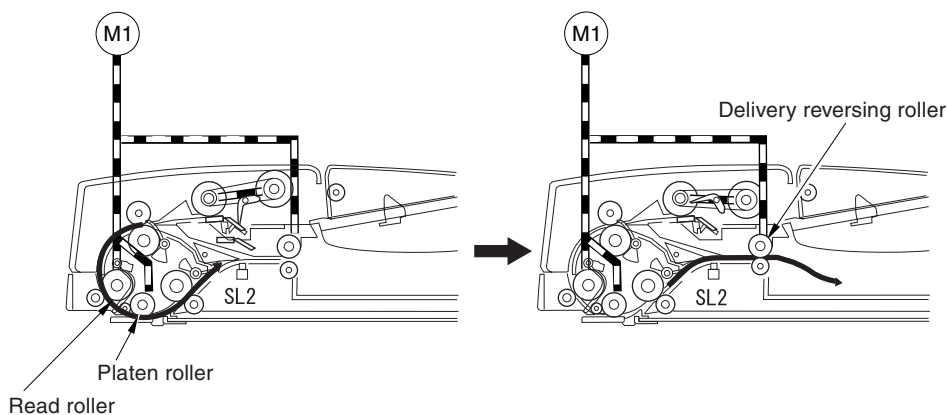

F-2-26

#### b. Reversal/Feed 1

When the trailing edge of the original moves past the delivery reversal sensor (PI\*), the feed motor (M1) stops; immediately thereafter, the feed motor starts to rotate in reverse so that the original is moved to and stopped at the registration roller. The locking solenoid (SL1) then goes off to free the delivery reversing roller.

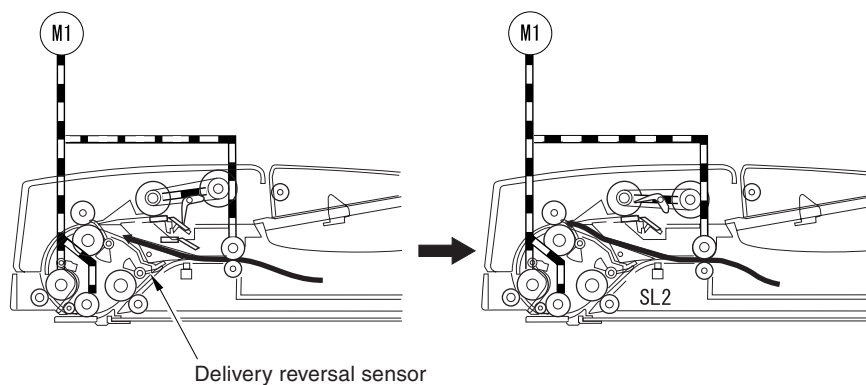

F-2-27

#### c. Reversal/Feed 2

The feed motor (M1) rotates to move the original as far as read standby position; by this time, the original has already

been turned over, and the machine goes to read, delivery, and feed modes.

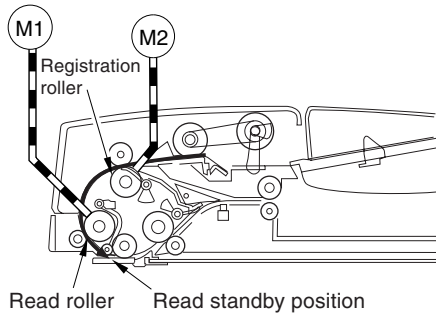

F-2-28

### 2.5.2 Sequence of Operation

0001-0417

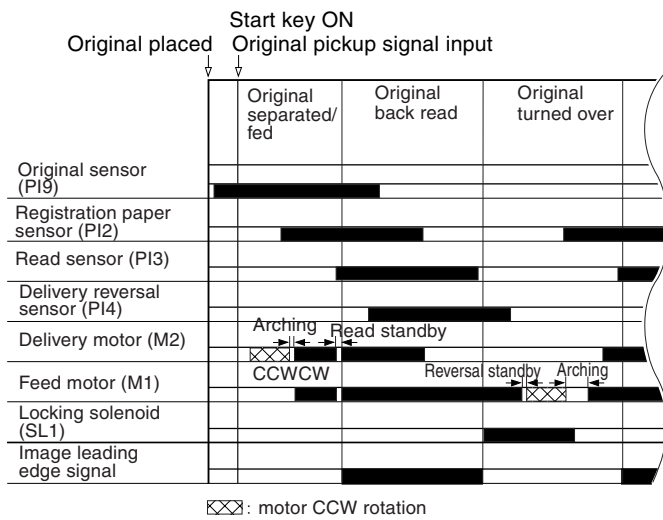

F-2-29

## 2.6 Document Feeding/Delivery

### 2.6.1 Basic Sequence of Operation

0001-0419

When the host machine finishes reading an original on its copyboard glass in stream reading mode, the machine moves it to the original delivery assembly as follows:

#### a. Moving the Original

The locking solenoid (OSL2) goes on so that the upper delivery reversing roller locks on to the upper delivery reversing roller; the rotation of the separation roller causes the original that has moved past the read position to be moved farther by the work of the delivery reversing roller.

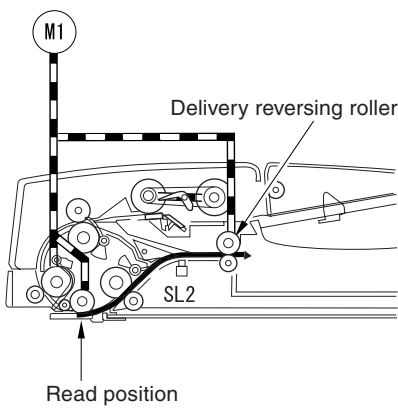

F-2-30

#### b. Delivering the Original to the Original Delivery Assembly

The drive (CW rotation) of the feed motor (M1) rotates the delivery reversing roller, which in turn moves the original to the original delivery assembly.

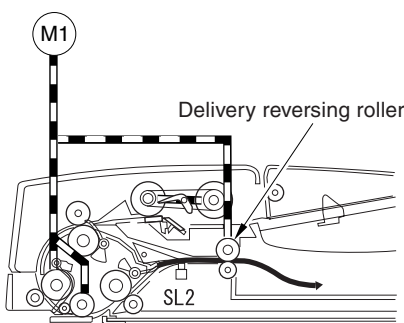

F-2-31

## 2.6.2 Sequence of Operation

0001-0426

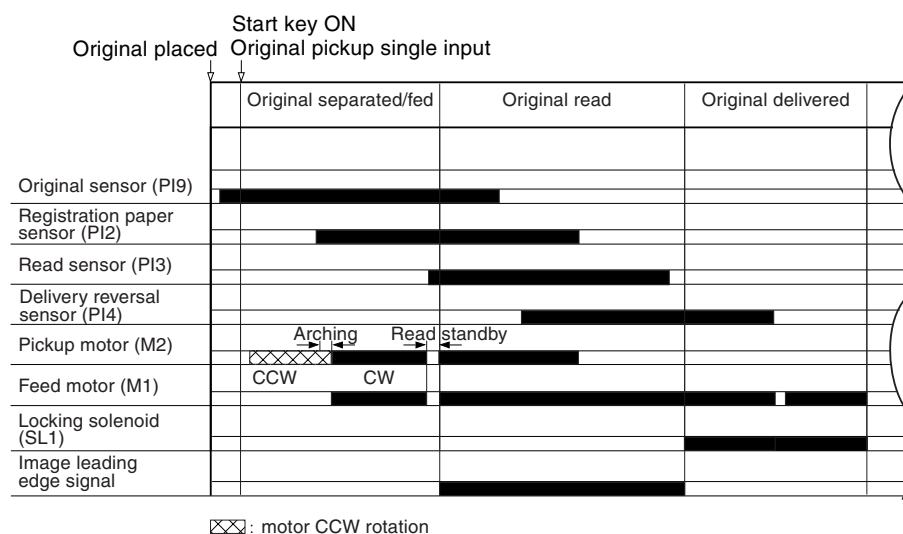

F-2-32

## 2.6.3 Controlling the Feed Motor (M1)

0001-0435

The following is the circuit used to control the feed motor (M1); the feed motor (M1) is a 4-phase stepping motor, and the circuit is used for the following:

- turning on/off the motor
- controlling the direction of motor rotation
- controlling the speed of motor rotation

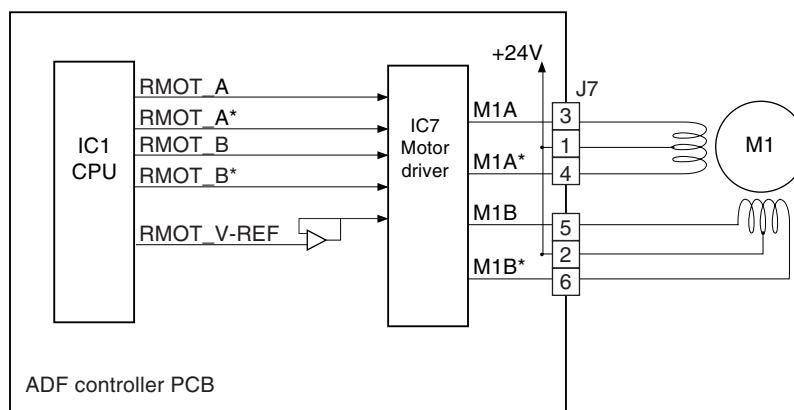

F-2-33

The CPU (IC1) on the ADF control PCB receives commands (magnification, operation mode, timing, etc.) from the host machine, and generates appropriate drive pulses to the feed motor according to these commands.

The feed motor is a stepping motor, and changes the direction and the speed of its rotation as the order and the frequency of the drive pulses (M1A, M1A\*; M1B, M1B\*) change.

T-2-12

<b>Signal</b>	<b>Description</b>
RMOT_A	drive pulse A
RMOT_A*	drive pulse A (reverse phase)
RMOT_B	drive pulse B
RMOT_B*	drive pulse B (reverse phase)
RMOT_V-REF	reference current setting

## 2.7 Detecting Jams

### 2.7.1 Jams

0001-0439

The machine uses the following sensors to detect original jams. It runs a check at such times as programmed in the ROM of the reader PCB, identifying a jam in relation to the presence/absence of paper over the sensor in question and communicating the result to the host machine using a code upon detection.

The jams identified by the machine are indicated in the host machine's service mode using in the form of code.

- Service Mode Screen of the Host Machine

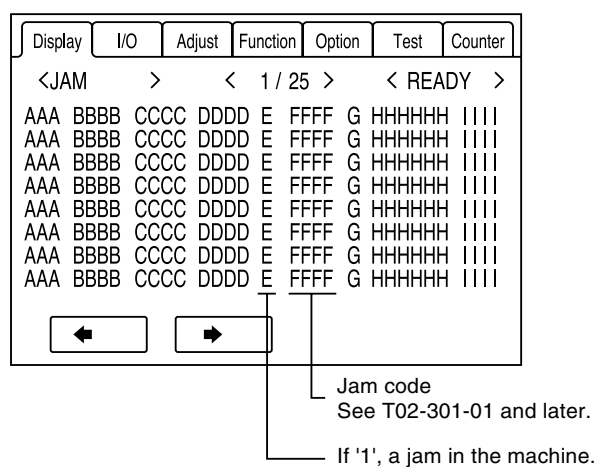

F-2-34

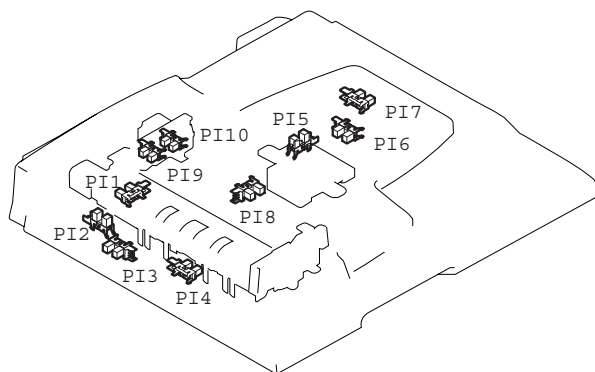

F-2-35

## 2.8 Power Supply

### 2.8.1 Power Supply

0001-0446

The following is an outline of how power is routed for the machine. The machine receives 2 channels of power (24 and 13 V) from the host machine, converting 5V using IC2 to generate drive for sensors and ADF controller PCB.

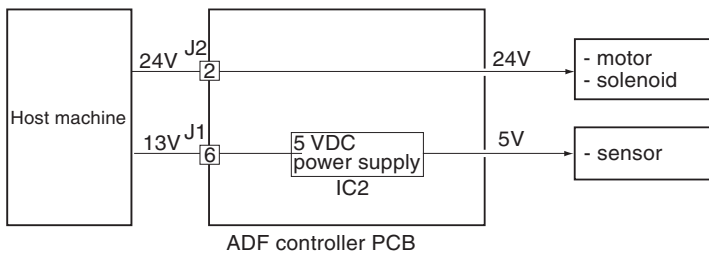

F-2-36



---

# Chapter 3    Installation

---



---

---

# Contents

3.1 Unpacking and Installation.....	3-1
3.1.1 Unpacking and Chacking the Components .....	3-1
3.1.1.1 Unpacking and Checking the Components .....	3-1
3.1.2 Installation Procedure.....	3-1
3.1.2.1 Turning Off the Host Machine .....	3-1
3.1.2.2 Installing the DADF .....	3-2
3.1.2.3 Cleaning the Copyboard Glass .....	3-3
3.1.3 Making Adjustments .....	3-3
3.1.3.1 Adjusting the Height.....	3-3
3.1.3.2 Turning On the Host Machine.....	3-4
3.1.3.3 Adjusting the Tray Width.....	3-4
3.1.3.4 Adjusting the Right Angles .....	3-5
3.1.3.5 Adjusting the Read Position .....	3-6
3.1.3.6 Adjusting the Magnification.....	3-7
3.1.3.7 Adjusting the Horizontal Registration.....	3-7
3.1.3.8 Adjusting the Trailing Edge Registration.....	3-7
3.1.3.9 Adjusting the White Level.....	3-8
3.1.4 Ataching the Labels etc. ....	3-8
3.1.4.1 Attaching the Size Label (small) .....	3-8
3.1.4.2 Attaching the Original Glass Cleaning Instructions Label.....	3-8
3.1.4.3 Mounting the Hinge Cover.....	3-9
3.1.4.4 Attaching the Warning Label (against finger trapping) .....	3-9
3.1.5 Checking the Operation.....	3-9
3.1.5.1 Checking the Operation.....	3-9



## 3.1 Unpacking and Installation

### 3.1.1 Unpacking and Checking the Components

#### 3.1.1.1 Unpacking and Checking the Components [0002-5569](#)

- 1) Open the shipping box used to hold the DADF-L1.
- 2) Remove the packing material used for the DADF-L1.
- 3) Check to see that none of the following is missing:

[2]	Face sticker	2
[3]	Stamp	1
[4]	Hinge cover (right)	1
[5]	Hinge cover (left)	1
[6]	Stepped screw (M5x6)	2
[7]	Stepped screw (M4x10)	3
[8]	Tapping screw (M3x8)	4
[9]	Size label (small)	1
[10]	Copyboard glass cleaning instructions label	1
[11]	Warning label	1

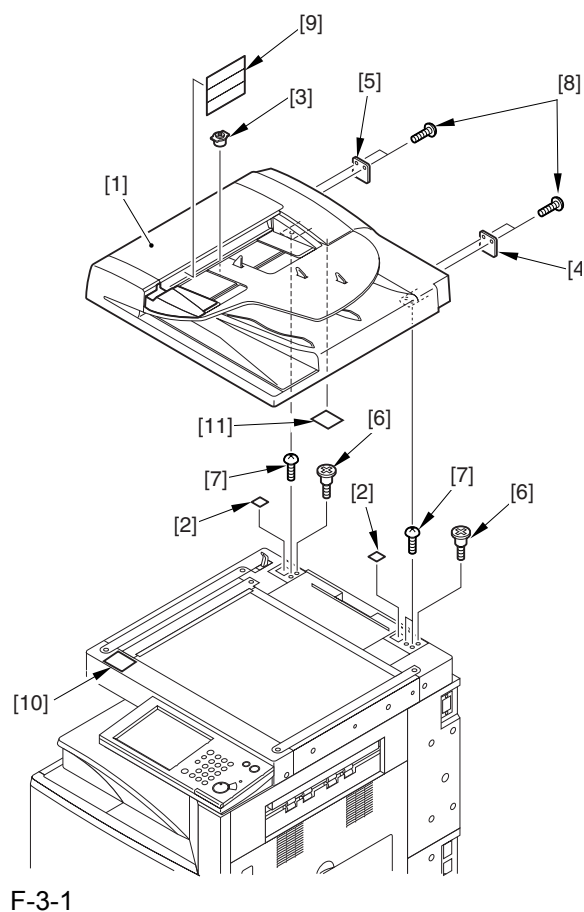

F-3-1

T-3-1

[1] DADF 1

### 3.1.2 Installation Procedure

#### 3.1.2.1 Turning Off the Host Machine [0003-6829](#)

**⚠** Be sure of the following before starting the work:

1. Turn off the control panel power switch.
2. Turn off the main power switch.
3. Disconnect the power cable (for the wall outlet).

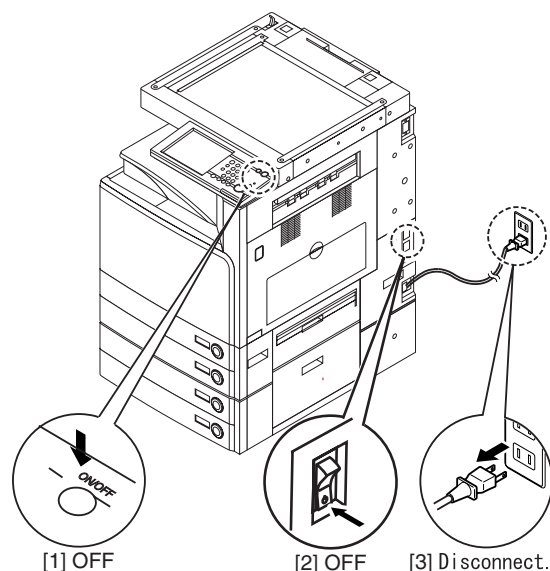

F-3-2

### 3.1.2.2 Installing the DADF 0002-5578

- 1) Remove the copyboard cover of the host machine; then, attach the face stickers over the hinge holes.

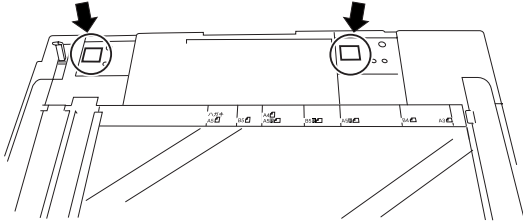

F-3-3

- 2) Remove the 5 screws from the top of the host machine. (You will no longer need these screws.)

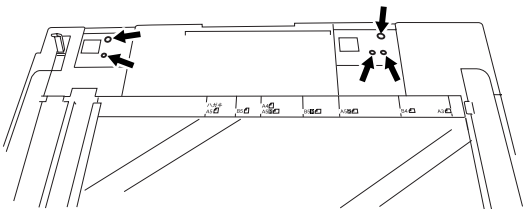

F-3-4

- 3) Fit 2 stepped screws (M5x6) [1] at the rear top of the host machine.

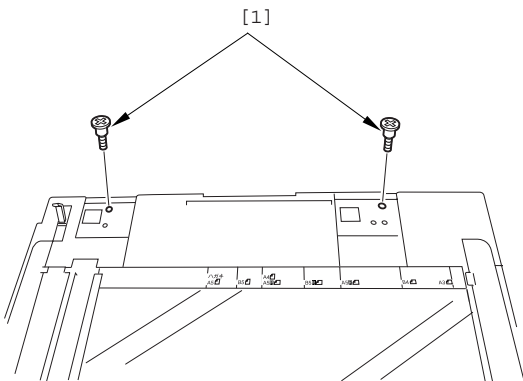

F-3-5

- 4) From behind the host machine, hook the hinges of the DADF on the stepped screws [1]; then, slide the DADF toward the front of the host machine.

**⚠** When holding the DADF, be sure not to touch the platen roller [2].

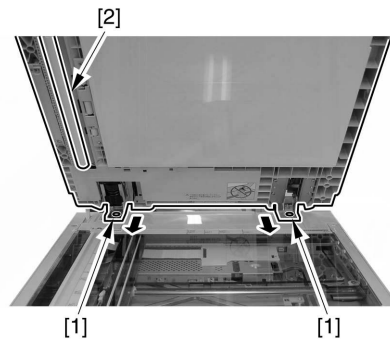

F-3-6

- 5) Using the stepped screw (M4x10) [2], fix the hinge in place; use 1 screw for the left, and use 2 screws for the right. Make sure that the left sides of the DADF and the host machine are flush when the DADF is closed.

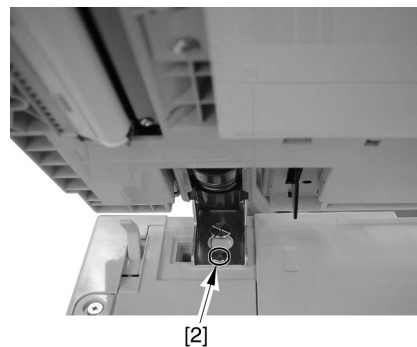

F-3-7

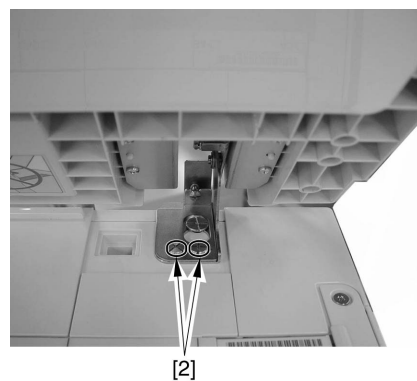

F-3-8

- 6) Open the pickup assembly cover and the jam access cover; then, using tweezers, fit the stamp. Be sure that the stamping side faces upward.

- ⚠ Jams can occur if the stamp is not firmly in place.  
Be sure to push it in until a click is felt.

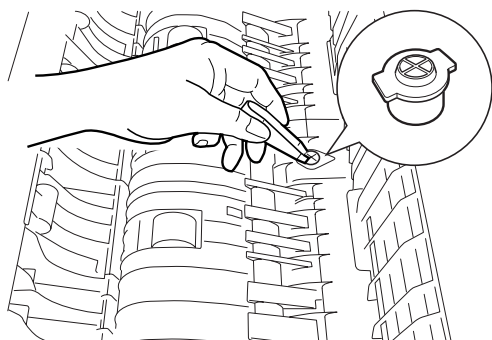

F-3-9

- 7) Close the pickup assembly cover.

- 8) Connect the cable of the DADF.

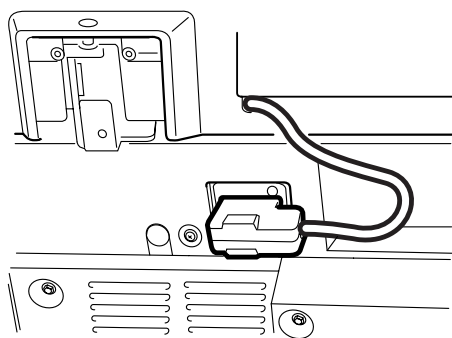

F-3-10

### 3.1.2.3 Cleaning the Copyboard

#### Glass

0002-5579

- 1) Wipe the glass of the original reading surface of the DADF with a cloth moistened with water. (Be sure the cloth is well wrung.)

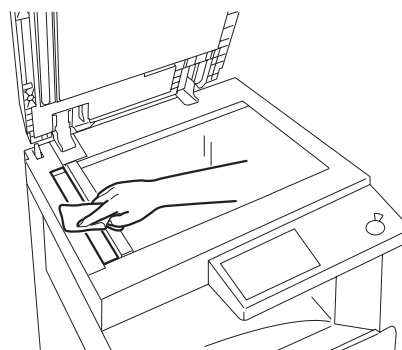

F-3-11

## 3.1.3 Making Adjustments

### 3.1.3.1 Adjusting the Height

0002-5590

#### 1. Making Pre-Checks

Check to see that the original butting segment on the pickup side is in full contact with the copyboard glass at both front and rear when the DADF is closed.

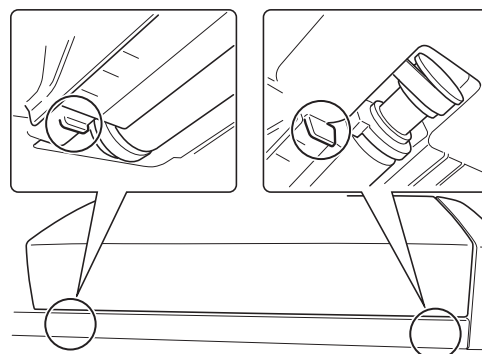

F-3-12

#### 2. Making Adjustments

- if the butting segment is not in contact at the front or the rear,

- 1) adjust the left hinge (see 3)
- 2) adjust the right hinge (see 4)
- 3) adjust the left hinge (see 3) or check the left hinge

- if the butting segment is not in contact at both sides

- 1) adjust the left hinge (see 3)
- 2) adjust the right hinge (see 4)
- 3) adjust the left hinge (see 3)
- 4) adjust the right hinge (see 4) or check the right

hinge

### 3. Adjusting the Height of the Left Hinge

- 1) Turn the height adjusting screw [1] of the left hinge to make adjustments.

**⚠** Be sure to loosen the fixing nut [2] prior to the adjustment, and tighten it back after the adjustment.

- if the front side is not in contact, turn the adjusting screw clockwise so that the front will be in contact with the glass.
- if the rear or both sides are not in contact, turn the adjusting screw counterclockwise so that the rear will be in contact with the glass.

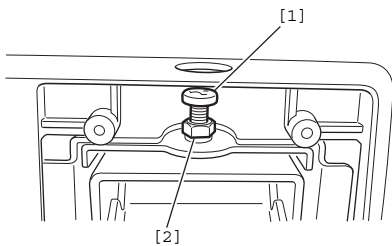

F-3-13

### 4. Adjusting the Height of the Right Hinge

- 1) Close the DADF, and check the following 2 points:
  - the rubber foot [1] must not be in contact with the cover of the reader unit (i.e., there must be a gap, A).
  - the original retaining sheet [2] is in contact with the copyboard glass.

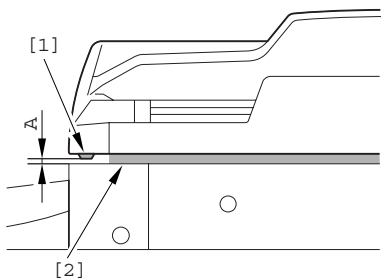

F-3-14

- 2) If the height is not correct, turn the height adjusting screw [1] of the right hinge to make adjustments.

**⚠** Be sure to loosen the fixing nut [2] prior to the adjustment, and tighten it back after the adjustment.

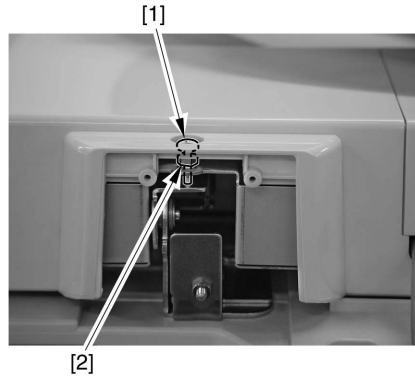

F-3-15

- turn the adjusting screw clockwise to increase the gap A.
- turn the adjusting screw counterclockwise to decrease the gap A.

- 3) Make the checks indicated in sep 1) under "adjusting the height of the left hinge"; if a discrepancy is found, make adjustments once gain.

### 3.1.3.2 Turning On the Host

Machine

0003-6832

- 1) Connect the power cable (for the wall outlet).
- 2) Turn on the main power switch.

### 3.1.3.3 Adjusting the Tray

Width

0002-5588

#### MEMO

The result of this adjustment is retained on the reader controller PCB. As such, unlike previous ADFs, you will need to make this adjustment at time of installation so that you will be able to store its result in the reader unit. If you omit this adjustment, the following will likely occur:

- wrong original size detection



---



---

**▲** Adjust the tray width by performing either AB-configuration adjustment or inch-configuration adjustment.

---

### 1. AB-Configuration Adjustment

#### 1) Start service mode.

##### Starting Service Mode

Press the User Mode key, press the 2 and 8 keys at the same time, and press the User Mode key once gain.

#### 2) Touch the following notations in sequence to bring up the Adjustment screen:

1 FEEDER

2 FUNCTION

3 TRY-A4 (to highlight)

#### 3) Adjust the tray side guide to the A4/A3 index.

#### 4) Touch [OK] to register the A4 width.

#### 5) Touch [TRY-A5R] to highlight.

#### 6) Adjust the tray side guide to the A5R index.

#### 7) Touch [OK] to register the A5R width.

#### 8) Press the Reset key twice to end service mode.

#### 9) Turn OFF the power switch on the operation panel and main power switch of the host machine in order.

#### 10) Turn ON the main power switch of the host machine.

### 2. Inch-Configuration Adjustment

#### 1) Start service mode.

##### Starting Service Mode

Press the User Mode key, press the 2 and 8 keys at the same time, and press the User Mode key once again.

#### 2) Touch the following notations in sequence to bring up the Adjustment screen:

1 FEEDER

2 FUNCTION

3 TRY-LTR (to highlight)

#### 3) Adjust the tray side guide to the LTR/11x17 index.

#### 4) Press [OK] to register the LTR width.

#### 5) Press [TRY-LTRR] to highlight

#### 6) Adjust the tray side guide to the STMT/LTRR/LGL INDEX.

#### 7) Touch [OK] to register the LTRR width.

#### 8) Press the Reset key twice to end service mode.

#### 9) Turn OFF the power switch on the operation panel and main power switch of the host machine in order.

#### 10) Turn ON the main power switch of the host machine.

### 3.1.3.4 Adjusting the Right Angles

0004-7257

#### 1) Place a test chart in the DADF, and make a copy.

#### MEMO

The Test Chart is printed on the back cover of the Installation

Procedure. Make a copy of the Chart or cut it off for use.

#### 2) Check the right angles of the image along the leading edge of the copy. Specifically, check the difference between dimensions A and B of the leading edge; if there is a difference, go to step 3) to make adjustments.

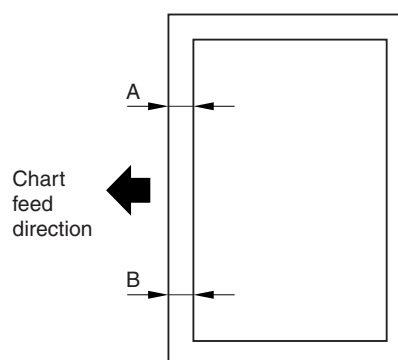

F-3-16

#### 3) Loosen the 3 screws [1] used to fix the hinge in place.

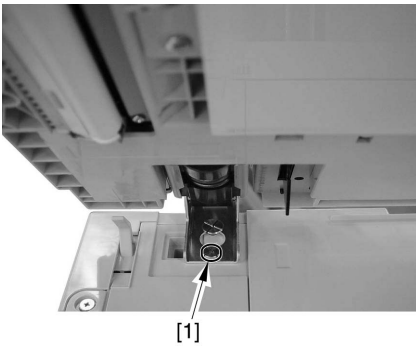

F-3-17

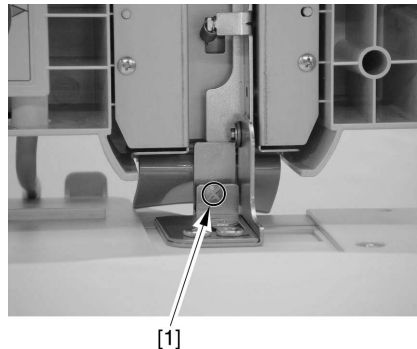

F-3-20

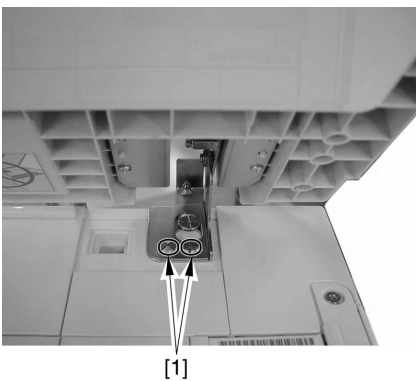

F-3-18

- 4) Turn the hinge adjusting screw [1] of the right hinge to adjust the angle of the DADF.

**⚠** Be sure to loosen the fixing nut [2] prior to the adjustment, and tighten it back after the adjustments.

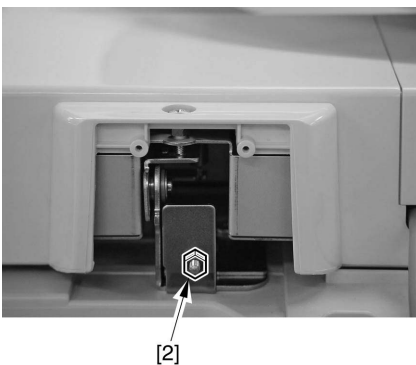

F-3-19

- If  $A > B$ , turn the adjustment screw clockwise.
  - if  $A < B$ , turn the adjusting screw counterclockwise.
- 5) Tighten back all fixing screws you loosened in step 3).

### 3.1.3.5 Adjusting the Read

Position

0002-5593

- 1) Start service mode.  
[Starting Service Mode]  
Press the User Mode key, press the 2 and 8 keys at the same time, and press the User Mode key once again.
- 2) On the Service Mode screen, touch the following notations in sequence to bring up the Adjustment screen:
  - 1 COPIER
  - 2 FUNCTION
  - 3 INSTALL
- 3) Press [STRD-POS] to highlight.
- 4) Touch [OK].  
A press on [OK] will cause the scanner to start a scan; in several seconds, the machine will end auto adjustment of the read position and indicate 'OK'.

- ⚠** If the machine fails auto adjustment and indicates 'NG', go through the following:
- (1) Clean the white roller of the DADF and the copyboard glass of the host machine; then, execute auto adjustment once again.
  - (2) If the auto adjustment operation still fails, start

service mode, and make adjustments manually:  
 COPIER>ADJUST>ADJ-XY>STRD-POS  
 (The default is '30'. Try changing the setting, and check output copy images to decide on the best setting.)

### 3.1.3.6 Adjusting the Magnification [0002-5594](#)

#### MEMO

The ADF's magnification is adjusted by comparing copy images made in stream reading mode and copy images made in copyboard cover mode (as this ADF is designed for color machines; on the other hand, the magnification of previous ADFs designed for black-and-white machines is adjusted by comparing copy images made in stream reading mode against their originals). If you adjust its magnification in the way done for previous ADFs, the following will likely occur:

- wrong ACS identification
- wrong black character processing identification

- 1) Place the Test Chart in the DADF, and make a copy. Refer to the output as copy B.
- 2) Place the Test Chart used in step 1) on the copyboard glass of the host machine, and make a copy. Refer to the output as copy A.
- 3) Compare copies A and B in terms of the length of the image in feed direction; as necessary, make adjustments in service mode.
  - if the image of copy B is shorter, decrease the setting (so that the speed at which originals are moved in stream reading mode will be reduced).
  - if the image of copy B is longer, increase the setting so that the speed at which originals are moved in stream reading mode will be increased).
 unit of adjustments: 0.1%
- 4) From the Service Mode screen, touch the following notations to bring up the Adjustment screen:
  - 1 FEEDER

- 2 ADJUST
- 3 LA-SPEED to highlight

### 3.1.3.7 Adjusting the Horizontal Registration [0002-5595](#)

- 1) Place the test chart in the DADF, and make a copy.
- 2) Compare the copy against the Test Chart for the horizontal registration; as necessary, make the following adjustments:

- if the image is displaced to the front, decrease the setting.
  - if the image is displaced to the rear, increase the setting.
- unit of adjustment: 0.1 mm

- 3) On the Service Mode screen, touch the following notations to bring up the Adjustment screen:

- 1 COPIER
- 2 ADJUST
- 3 ADJ-XY
- 4 ADJ-Y-DF

### 3.1.3.8 Adjusting the Trailing Edge Registration [0002-5597](#)

- 1) Place the Test Chart in the DADF, and make a copy.
- 2) Compare the copy against the Test Chart for the trailing edge registration; as necessary, make the following adjustments:

- if the image is displaced to the leading edge, decrease the setting.
  - if the image is displaced to the trailing edge, increase the setting.
- unit of adjustment: 0.1 mm

- 3) On the Service Mode screen, touch the following notations to bring up the Adjustment screen:

- 1 FEEDER
- 2 ADJUST
- 3 DOCST

### 3.1.3.9 Adjusting the White

Level 0002-5598

#### MEMO

This is a new item of adjustment in which the white level of images made in stream reading mode are matched with the white level of images made in copyboard cover mode (as this ADF is designed for color machines). If you omit this adjustment, the following will likely occur:

- inappropriate reproduction of background density in images made in stream reading mode
- wrong speck detection in stream reading mode

- 1) Place paper (of the type most often used by the user) on the copyboard glass, and close the DADF.
- 2) Touch the following notations in sequence to bring up the Adjustment screen:

1 COPIER

2 FUNCTION

3 CCD

3) Press [DF-WLVL1] to highlight.

4) Press [OK].

Automatic adjustment starts; if it ends successfully, the screen shows [OK!].

5) Remove the paper from the copyboard glass, and place it on the original tray of the DADF.

6) Press [DF-WLVL2] on the touch panel to highlight.

7) Press [OK].

- The machine executes auto adjustment (duplex stream reading).

- When the adjustment ends normally, the machine indicates 'OK!' on the screen.

8) Press the Reset key twice to end service mode.

### 3.1.4 Ataching the Labels etc.

#### 3.1.4.1 Attaching the Size

Label (small) 0002-5605

**▲**The size label (small) has been designed to assist

size adjustment by offering various angles of view.

1) Adjust the side guide (rear) [1] to the A4/A3 index or the LTR/11x17 index [2].

2) Attach the label of the paper configuration that matches the size label (small) [3].

Try moving the label back and forth in the direction of the arrow [5] so that the index [4] of the side guide (front) matches the index of the size label to suit the angle of view of the user.

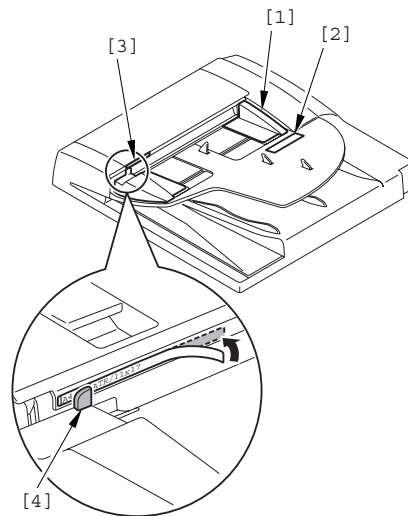

F-3-21

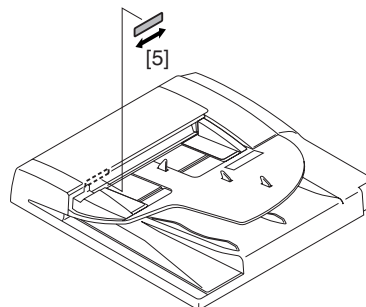

F-3-22

#### 3.1.4.2 Attaching the Original

Glass Cleaning Instructions

Label 0002-5651

1) Attach the original glass cleaning instructions label [1] to the front cover of the reader unit.

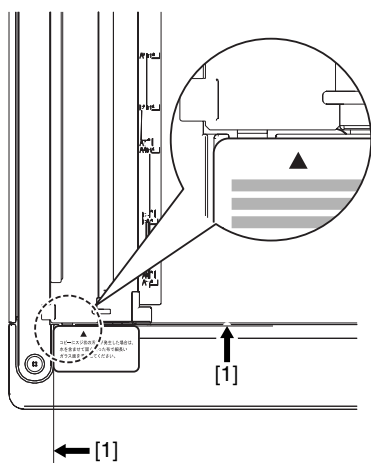

F-3-23

[1] Butted.

### 3.1.4.3 Mounting the Hinge

Cover [0002-5676](#)

- 1) Mount the hinge cover to the left/right hinge assembly using tapping screws (M3x8). Be sure to attach the sheet on the inside and the rubber plate to the outside.

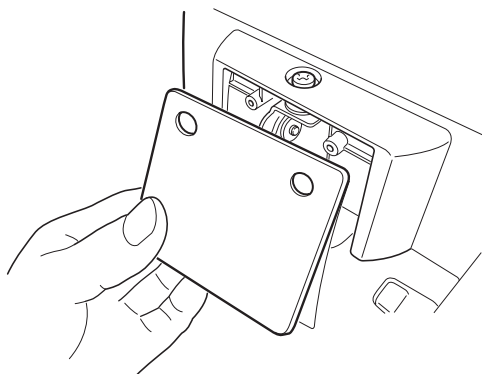

F-3-24

### 3.1.4.4 Attaching the Warning

Label (against finger trapping) [0004-8558](#)

- 1) Attach the warning label for the appropriate language to the DADF lower cover as shown.

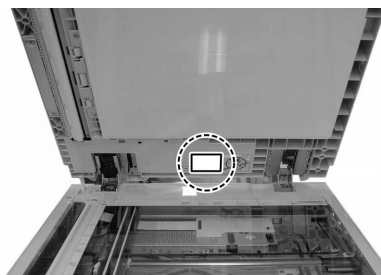

F-3-25

## 3.1.5 Checking the Operation

### 3.1.5.1 Checking the Operation [0002-5609](#)

1) Make the following checks:

1. Place an original in the DADF, and open and close the feeder cover to see if the original placement LED goes on and off correctly.
2. Make single-sided and double-sided codes to see if the operations are normal.
3. If fax mode is to be used, send faxes to see if the stamping operation is normal.



---

# Chapter 4    Parts

## Replacement Procedure

---





---

---

# Contents

4.1 Removing from the Host Machine .....	4-1
4.1.1 Feeder .....	4-1
4.1.1.1 Disconnecting from the Host Machine.....	4-1
4.2 Drive System .....	4-2
4.2.1 Pickup Motor .....	4-2
4.2.1.1 Removing the Rear Cover .....	4-2
4.2.1.2 Removing the Pickup Motor .....	4-2
4.2.1.3 Mounting the Pickup Motor .....	4-2
4.2.2 Feed Motor .....	4-3
4.2.2.1 Removing the Rear Cover .....	4-3
4.2.2.2 Removing the Feed Motor.....	4-3
4.2.2.3 Mounting the Feed Motor.....	4-4
4.2.3 Timing Belt/Pulley .....	4-5
4.2.3.1 Disconnecting from the Host Machine.....	4-5
4.2.3.2 Removing the Rear Cover .....	4-5
4.2.3.3 Removing the Front Cover .....	4-5
4.2.3.4 Removing the Feeder Cover .....	4-6
4.2.3.5 Removing the Pickup Motor .....	4-6
4.2.3.6 Removing the Feed Motor.....	4-6
4.2.3.7 Detaching the Timing Belt and the Pulley .....	4-7
4.3 Document Feeding System.....	4-9
4.3.1 Pickup Roller Unit.....	4-9
4.3.1.1 Removing the Front Cover .....	4-9
4.3.1.2 Removing the Feeder Cover.....	4-9
4.3.1.3 Removing the Pickup Roller Unit .....	4-9
4.3.1.4 Mounting the Pickup Roller Unit .....	4-9
4.3.2 Pickup Roller/Separation Roller.....	4-10
4.3.2.1 Removing the Front Cover .....	4-10
4.3.2.2 Removing the Feeder Cover.....	4-10
4.3.2.3 Removing the Pickup Roller Unit .....	4-11
4.3.2.4 Removing the Pickup Roller and the Separation Roller.....	4-11
4.3.3 Separation Plate/Separation Pad.....	4-11
4.3.3.1 Removing the Separation Plate and the Separation Pad.....	4-11
4.3.3.2 Adjusting the Separation Pressure.....	4-12
4.3.4 Upper Registration Roller .....	4-12
4.3.4.1 Removing the Front Cover .....	4-12
4.3.4.2 Removing the Feeder Cover.....	4-13
4.3.4.3 Removing the Upper Registration Roller .....	4-13
4.3.5 Lower Registration Roller.....	4-13
4.3.5.1 Removing the Rear Cover .....	4-13
4.3.5.2 Removing the Front Cover .....	4-14
4.3.5.3 Removing the Feeder Cover.....	4-14
4.3.5.4 Removing the Pickup Motor .....	4-14
4.3.5.5 Removing the Feed Motor.....	4-15

4.3.5.6 Disassembling the Drive System .....	4-15
4.3.5.7 Removing the Feeder Unit.....	4-16
4.3.5.8 Removing the Upper Delivery Reversing Roller.....	4-17
4.3.5.9 Removing the Platen Guide L.....	4-17
4.3.5.10 Removing the Read Roller 1.....	4-18
4.3.5.11 Removing the Read Roller 2.....	4-19
4.3.5.12 Removing the Lower Registration Roller.....	4-19
4.3.6 Delivery Reversing Roller (upper) .....	4-20
4.3.6.1 Removing the Rear Cover.....	4-20
4.3.6.2 Removing the Front Cover .....	4-20
4.3.6.3 Removing the Feeder Cover .....	4-21
4.3.6.4 Removing the Pickup Motor.....	4-21
4.3.6.5 Removing the Feed Motor .....	4-21
4.3.6.6 Disassembling the Drive System .....	4-22
4.3.6.7 Removing the Feeder Unit.....	4-23
4.3.6.8 Removing the Upper Delivery Reversing Roller.....	4-24
4.3.7 Read Roller 1 .....	4-24
4.3.7.1 Removing the Front Cover .....	4-24
4.3.7.2 Removing the Rear Cover.....	4-24
4.3.7.3 Removing the Feeder Cover .....	4-25
4.3.7.4 Removing the Pickup Motor.....	4-25
4.3.7.5 Removing the Feed Motor .....	4-26
4.3.7.6 Disassembling the Drive System .....	4-26
4.3.7.7 Removing the Feeder Unit.....	4-27
4.3.7.8 Removing the Platen Guide L.....	4-28
4.3.7.9 Removing the Read Roller 1 .....	4-28
4.3.8 Read Roller 2 .....	4-30
4.3.8.1 Removing the Front Cover .....	4-30
4.3.8.2 Removing the Rear Cover.....	4-30
4.3.8.3 Removing the Feeder Cover .....	4-30
4.3.8.4 Removing the Pickup Motor.....	4-31
4.3.8.5 Removing the Feed Motor .....	4-31
4.3.8.6 Disassembling the Drive System .....	4-32
4.3.8.7 Removing the Feeder Unit.....	4-33
4.3.8.8 Removing the Read Roller 2.....	4-34
4.3.9 Platen Roller .....	4-34
4.3.9.1 Removing the Front Cover .....	4-34
4.3.9.2 Removing the Rear Cover.....	4-34
4.3.9.3 Removing the Feeder Cover .....	4-35
4.3.9.4 Removing the Pickup Motor.....	4-35
4.3.9.5 Removing the Feed Motor .....	4-36
4.3.9.6 Disassembling the Drive System .....	4-36
4.3.9.7 Removing the Feeder Unit.....	4-37
4.3.9.8 Removing the Platen Guide L.....	4-38
4.3.9.9 Removing the Platen Roller.....	4-38
4.3.10 Delivery Reversing Roller (lower) .....	4-39
4.3.10.1 Removing the Lower Delivery Reversing Roller .....	4-39
4.3.10.2 Removing the Rear Cover.....	4-39
4.3.10.3 Removing the Front Cover .....	4-40

---

---

4.3.10.4 Removing the Feeder Cover .....	4-40
4.3.10.5 Removing the Pickup Motor .....	4-40
4.3.10.6 Removing the Feed Motor .....	4-41
4.3.10.7 Disassembling the Drive System .....	4-41
4.3.10.8 Removing the Feeder Unit .....	4-42
4.3.10.9 Removing the Lower Delivery Reversing Roller Unit .....	4-43
4.3.11 Read Roller Roll .....	4-43
4.3.11.1 Removing the Read Roller 2 Roll .....	4-43
4.3.12 Separation Guide Sheet .....	4-44
4.3.12.1 Before Replacing the Separation Guide Sheet .....	4-44
4.3.12.2 Removing the Front Cover .....	4-44
4.3.12.3 Removing the Feeder Cover .....	4-44
4.3.12.4 Replacing the Separation guide Sheet .....	4-45
4.3.13 Feed Roller Guide .....	4-45
4.3.13.1 Repacking the Feed Roll Guide (dust-collecting tape) .....	4-45
4.4 Electrical System .....	4-46
4.4.1 ADF Controller PCB .....	4-46
4.4.1.1 Removing the Rear Cover .....	4-46
4.4.1.2 Removing the ADF Controller PCB .....	4-46
4.4.2 Inner Sensor of Feed Unit .....	4-46
4.4.2.1 Removing the Front Cover .....	4-46
4.4.2.2 Removing the Rear Cover .....	4-47
4.4.2.3 Removing the Feeder Cover .....	4-47
4.4.2.4 Removing the Pickup Motor .....	4-47
4.4.2.5 Removing the Feeder Motor .....	4-48
4.4.2.6 Disassembling the Drive System .....	4-48
4.4.2.7 Removing the Feeder Unit .....	4-50
4.4.2.8 Removing the Upper Delivery Reversing Roller .....	4-50
4.4.2.9 Removing the Platen Guide L .....	4-51
4.4.2.10 Removing the Reader Roller 1 .....	4-51
4.4.2.11 Removing the Read Roller 2 .....	4-52
4.4.2.12 Removing the Platen Roller .....	4-52
4.4.2.13 Removing the Feeder Unit Inside Sensor .....	4-53
4.4.3 Document Width Volume .....	4-53
4.4.3.1 Removing the Front Cover .....	4-53
4.4.3.2 Removing the Original Width Volume .....	4-54
4.4.3.3 Mounting the Original Width Volume .....	4-54
4.4.4 ADF Open/Closed Sensor .....	4-54
4.4.4.1 Removing the Open/Closed sensor .....	4-54
4.4.5 Cover Open/Closed Sensor .....	4-55
4.4.5.1 Removing the Rear Cover .....	4-55
4.4.5.2 Removing the Cover Open/Closed Sensor .....	4-55
4.4.6 Document Set Sensor .....	4-56
4.4.6.1 Removing the Rear Cover .....	4-56
4.4.6.2 Removing the Original Placement Sensor .....	4-56
4.4.7 Pressurization Solenoid .....	4-56
4.4.7.1 Removing the Rear Cover .....	4-56
4.4.7.2 Remove the screw [1], and detach the ADF controller PCB .....	4-57
4.4.7.3 Removing the Locking Solenoid .....	4-57

---

## 4.1 Removing from the Host Machine

---

### 4.1.1 Feeder

#### 4.1.1.1 Disconnecting from the

Host Machine

0003-8750

- 1) Turn off the host machine.
- 2) Disconnect the communication cable [1] of the machine from the host machine.

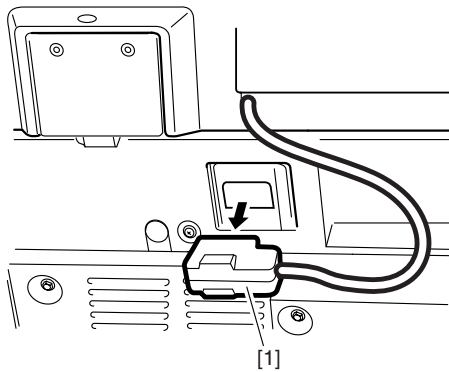

F-4-1

- 3) Remove the 3 stepped screws [1] and the other screw [2].
- 4) Slide the machine toward the rear, and lift it to detach.

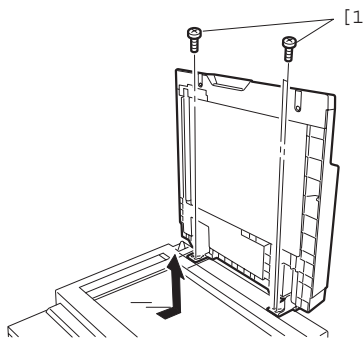

F-4-2

## 4.2 Drive System

### 4.2.1 Pickup Motor

#### 4.2.1.1 Removing the Rear Cover

0001-0869

- 1) Open the feeder cover and the original pickup tray; then, move the screw [1].

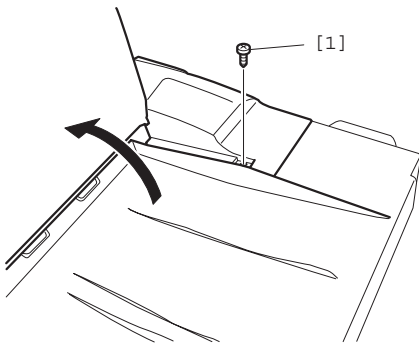

F-4-3

- 2) Remove the 2 screws [2], and detach the rear cover [3].

**⚠** Be sure to detach the cover while feeding the 3 claws [4] of the rear cover.

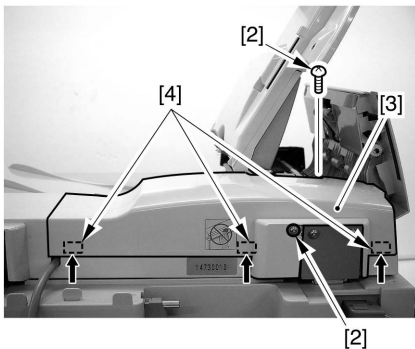

F-4-4

#### 4.2.1.2 Removing the Pickup Motor

0001-0942

- 1) Disconnect the connector [1].

- 2) Remove the 2 fixing screws [2] of the adjusting plate.

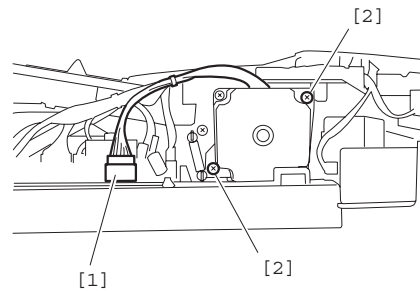

F-4-5

- 3) Remove the tension spring [3] using tweezers; then, remove the stepped screw [4], and detach the pickup motor [5] together with the adjusting plate.

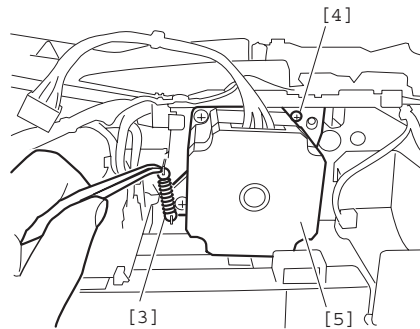

F-4-6

#### 4.2.1.3 Mounting the Pickup Motor

Motor

0001-0867

- 1) Mount the motor so that the motor pulley and the timing belt are fully matched then, tighten the screw [1].
- 2) Fit the tension spring [2] to the adjusting plate and the motor base.

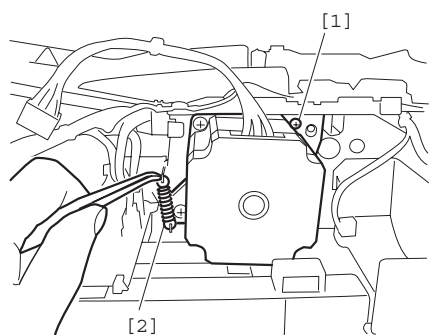

F-4-7

- 3) Fix the adjusting plate in place using 2 screws [3], and connect the connector [4].

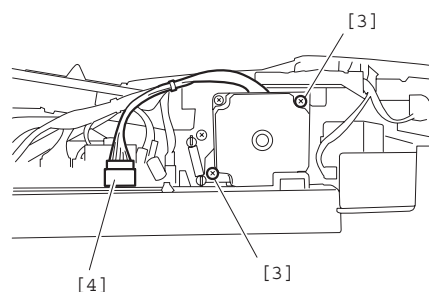

F-4-8

## 4.2.2 Feed Motor

### 4.2.2.1 Removing the Rear Cover

0001-0868

- 1) Open the feeder cover and the original pickup tray; then, move the screw [1].

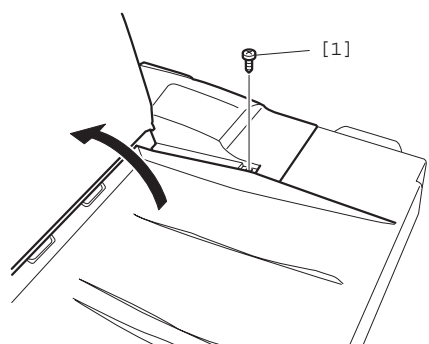

F-4-9

- 2) Remove the 2 screws [2], and detach the rear cover

[3].

- ⚠ Be sure to detach the cover while feeding the 3 claws [4] of the rear cover.

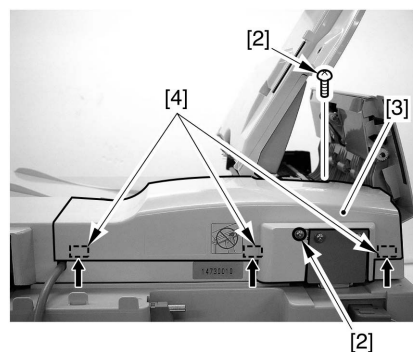

F-4-10

### 4.2.2.2 Removing the Feed Motor

0001-0875

- 1) Free the 4 claws [1] of the harness guide; then, disconnect the connector [2].

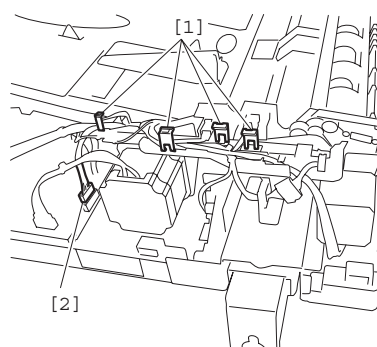

F-4-11

- 2) Remove the tension spring [3].

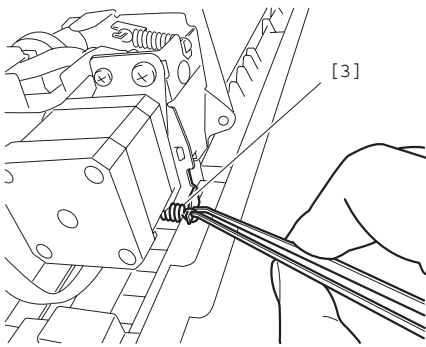

F-4-12

3) Remove the 2 screws [4] and the stepped screw [5]; then, detach the feed motor [6] together with the adjusting plate [7].

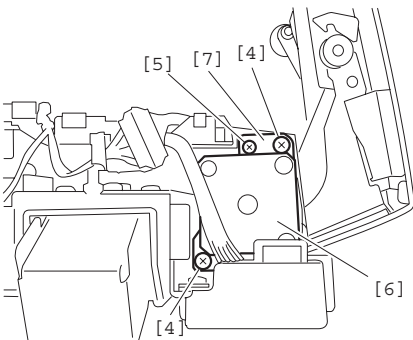

F-4-13

#### 4.2.2.3 Mounting the Feed Motor

0001-0880

1) Mount the feed motor [1] together with the adjusting plate [2]; then, fit the toner spring [3] and the stepped screw [4].

It will be difficult to fit the tension spring if not done now; hook it on the adjusting plate first.

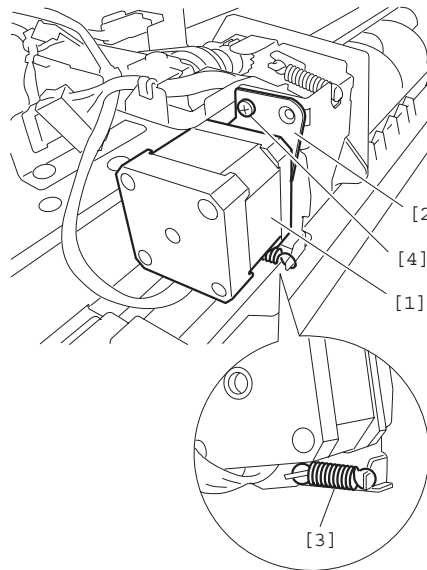

F-4-14

2) While pushing the feed motor [5] to the left, attach the timing belt [6] on the pulley.

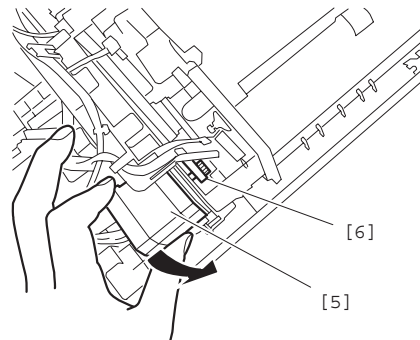

F-4-15

3) Fix the adjusting plate in place using 2 fixing screws [7].

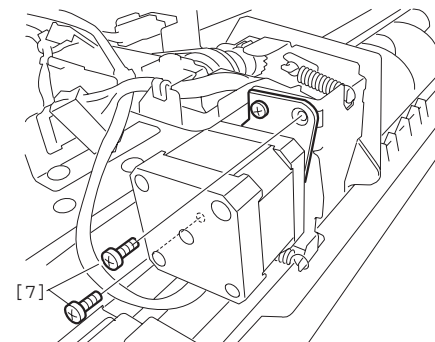

F-4-16

## 4.2.3 Timing Belt/Pulley

### 4.2.3.1 Disconnecting from the Host Machine

0002-0356

- 1) Turn off the host machine.
- 2) Disconnect the communication cable [1] of the machine from the host machine.

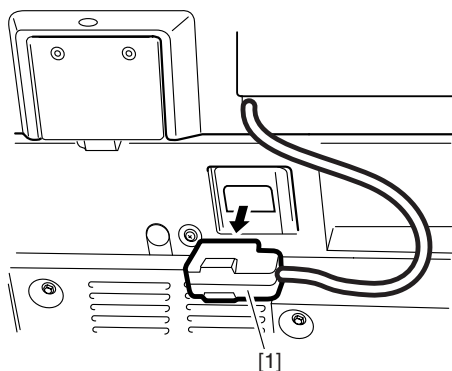

F-4-17

- 3) Remove the 3 stepped screws [1] and the other screw [2].
- 4) Slide the machine toward the rear, and lift it to detach.

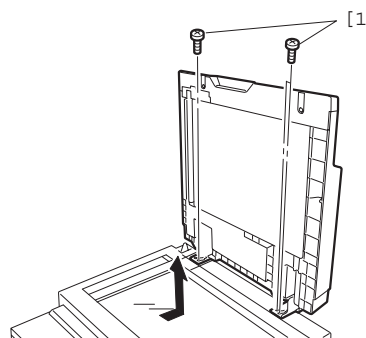

F-4-18

### 4.2.3.2 Removing the Rear Cover

0001-0885

- 1) Open the feeder cover and the original pickup tray; then, move the screw [1].

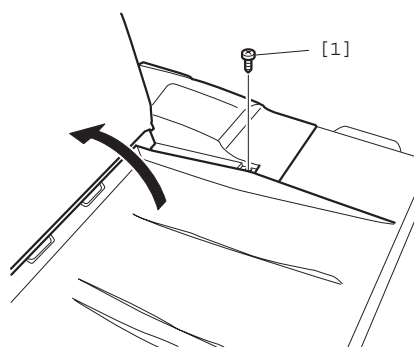

F-4-19

- 2) Remove the 2 screws [2], and detach the rear cover [3].

▲ Be sure to detach the cover while feeding the 3 claws [4] of the rear cover.

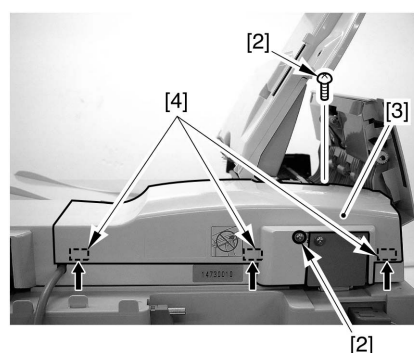

F-4-20

### 4.2.3.3 Removing the Front Cover

0001-0886

- 1) Open the feeder cover [1], and remove the screw [2].



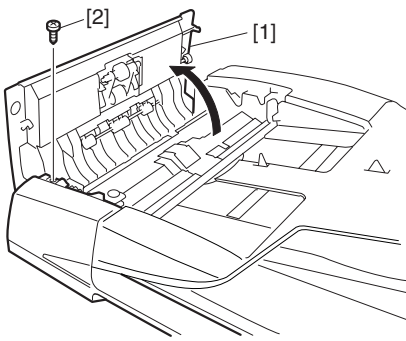

F-4-21

- 2) Remove the 2 screws [3], and detach the front cover [4].

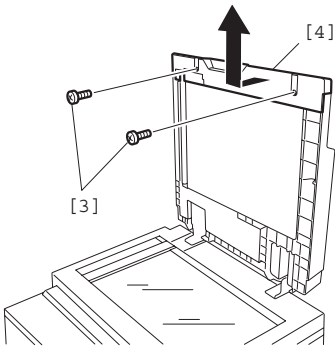

F-4-22

#### 4.2.3.4 Removing the Feeder Cover

0001-0916

- 1) Remove the screw [1] and the positioning pin [2]; then, detach the feeder cover [3].

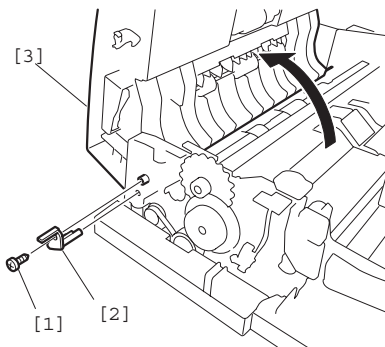

F-4-23

#### 4.2.3.5 Removing the Pickup Motor

0001-0917

- 1) Disconnect the connector [1].
- 2) Remove the 2 fixing screws [2] of the adjusting plate.

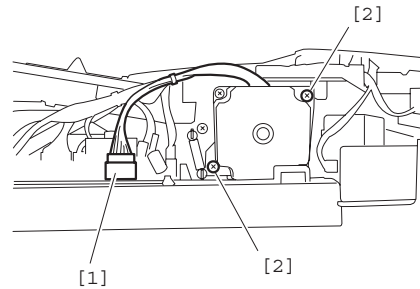

F-4-24

- 3) Remove the tension spring [3] using tweezers; then, remove the stepped screw [4], and detach the pickup motor [5] together with the adjusting plate.

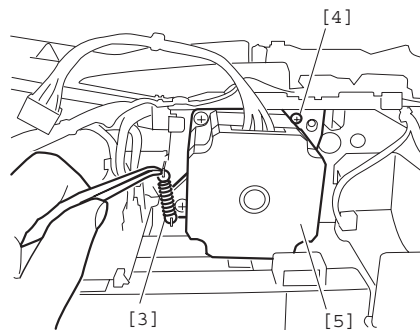

F-4-25

#### 4.2.3.6 Removing the Feed Motor

0003-9235

- 1) Free the 4 claws [1] of the harness guide; then, disconnect the connector [2].

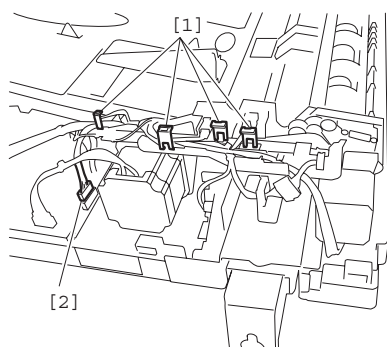

F-4-26

2) Remove the tension spring [3].

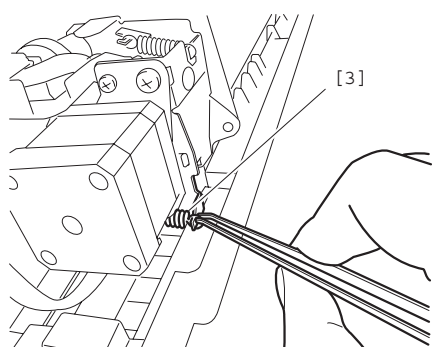

F-4-27

3) Remove the 2 screws [4] and the stepped screw [5]; then, detach the feed motor [6] together with the adjusting plate [7].

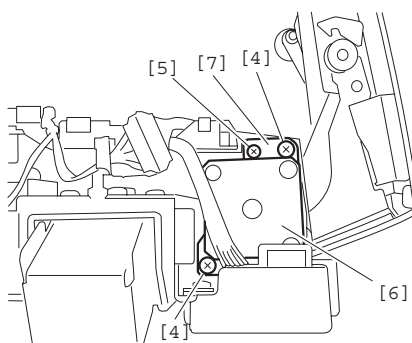

F-4-28

#### 4.2.3.7 Detaching the Timing Belt and the Pulley

0001-0922

1) Disconnect the 2 connectors [1], and remove the grounding fixing screw [3]; then, slide the harness

guide slightly to the left, and lift it.

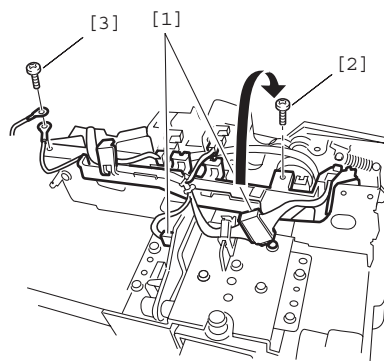

F-4-29

2) Remove the 4 screws [4] and the other screw [5]; then, detach the left hinge unit.

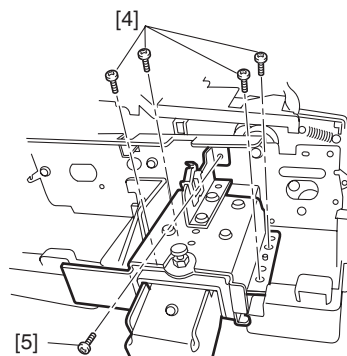

F-4-30

3) Remove the screw [6], and detach the original placement sensor [7] together with the bracket; then, disconnect the connector [8].

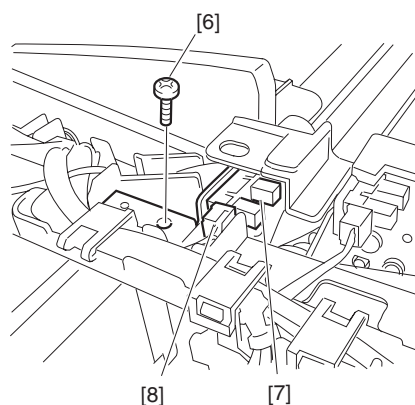

F-4-31

- 4) Remove the 3 screws [9] and the 2 other screws; then, detach the motor base [11].

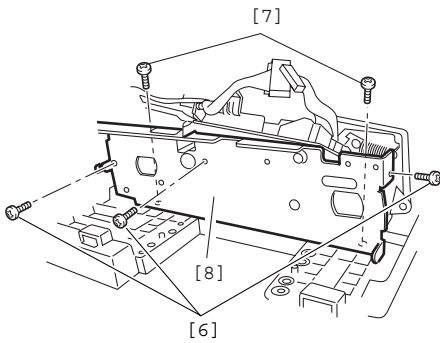

F-4-32

- 5) Detach the motor drive timing belt [12] [13].

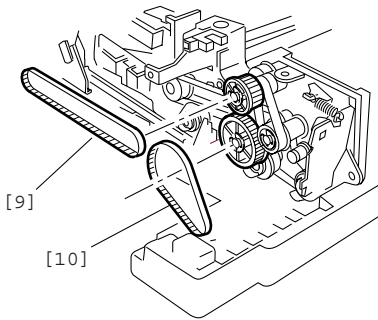

F-4-33

- 6) Remove the 3 E-rings [14], and detach the 2 pulleys [15], one-way clutch [16], and timing belt [17] [18].

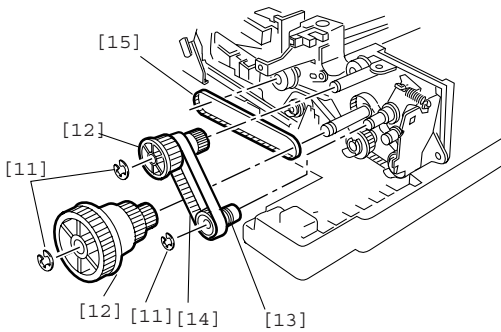

F-4-34

- ⚠** Loosen the screw [20] of the tension arm [19]; then, force the arm clockwise to mount it. When you have attached the timing belt, tighten the screw [20].

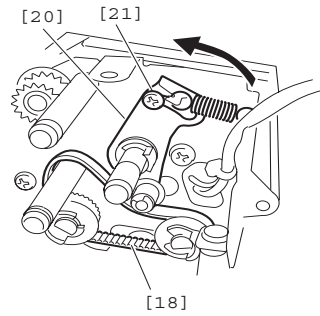

F-4-35

## 4.3 Document Feeding System

### 4.3.1 Pickup Roller Unit

#### 4.3.1.1 Removing the Front Cover

0002-0358

- 1) Open the feeder cover [1], and remove the screw [2].

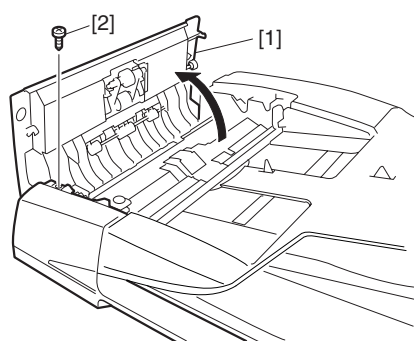

F-4-36

- 2) Remove the 2 screws [3], and detach the front cover [4].

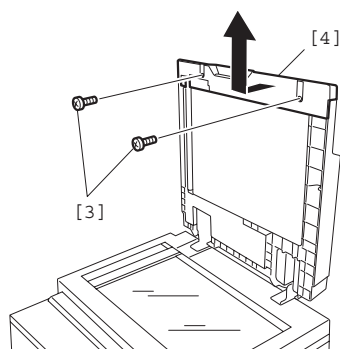

F-4-37

#### 4.3.1.2 Removing the Feeder Cover

0001-0946

- 1) Remove the screw [1] and the positioning pin [2]; then, detach the feeder cover [3].

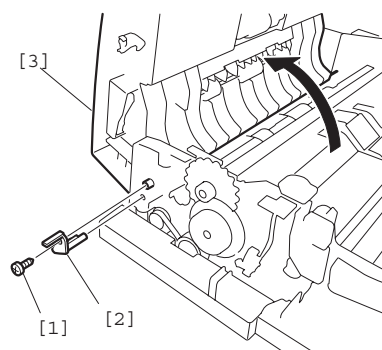

F-4-38

#### 4.3.1.3 Removing the Pickup Roller Unit

0001-0948

- 1) Remove the 4 screws [1], and detach the feeder cover [2].

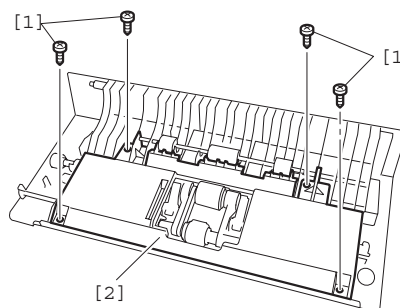

F-4-39

- 2) Remove the 2 E-rings [3] and the 2 bushings [4]; then, detach the pickup roller unit [5].

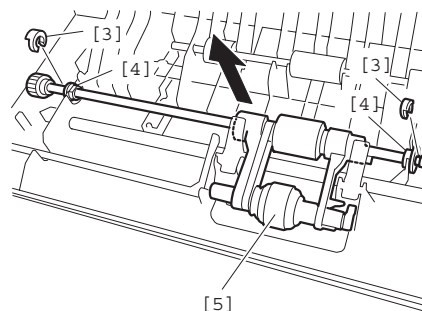

F-4-40

#### 4.3.1.4 Mounting the Pickup Roller Unit

0001-0953

- 1) Shift up the left/right stop arm [1], and mount the

pickup unit so that the stopper arm is between the separation roller shaft [2] and the pickup roller shaft [3].

**▲** Make sure that the lever segment of the stop lever [4] is under the stopper arm [1].

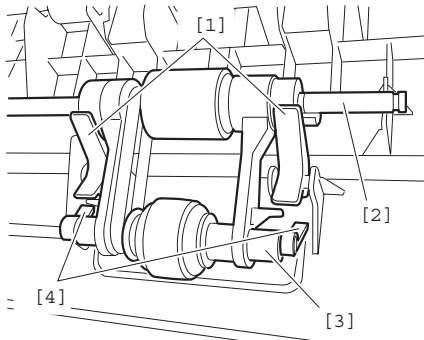

F-4-41

- 2) Secure the pickup roller unit in place using 2 resin E-rings [5] and 2 bushings.
- 3) Mount the inside cover of the feeder cover back into place; then, fix it in place using 4 screws.

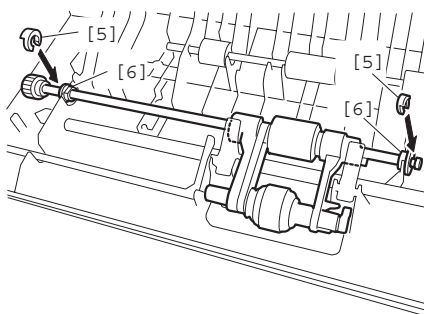

F-4-42

## 4.3.2 Pickup Roller/Separation Roller

### 4.3.2.1 Removing the Front Cover

0002-0359

- 1) Open the feeder cover [1], and remove the screw [2].

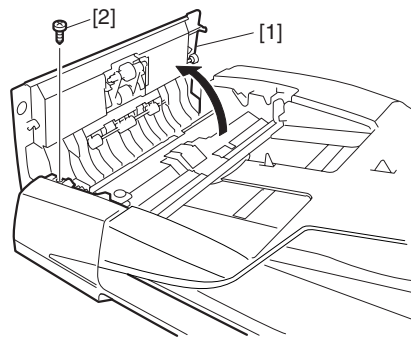

F-4-43

- 2) Remove the 2 screws [3], and detach the front cover [4].

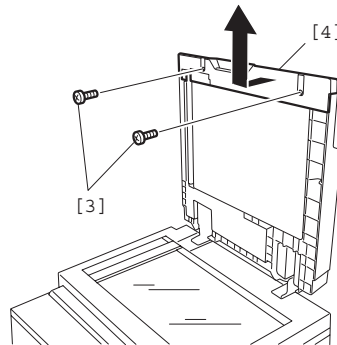

F-4-44

### 4.3.2.2 Removing the Feeder Cover

Cover

0001-0958

- 1) Remove the screw [1] and the positioning pin [2]; then, detach the feeder cover [3].

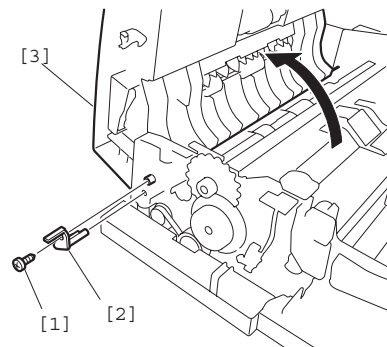

F-4-45

### 4.3.2.3 Removing the Pickup

#### Roller Unit

0001-0959

- 1) Remove the 4 screws [1], and detach the feeder cover [2].

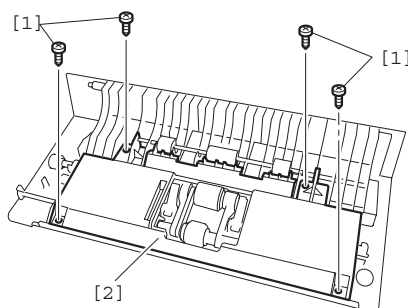

F-4-46

- 2) Remove the 2 E-rings [3] and the 2 bushings [4]; then, detach the pickup roller unit [5].

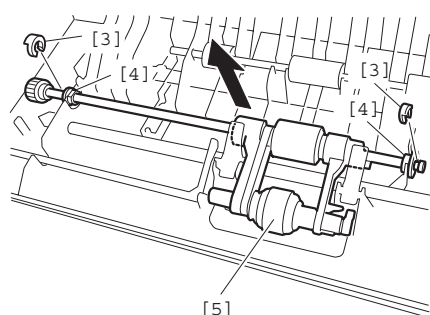

F-4-47

### 4.3.2.4 Removing the Pickup Roller and the Separation Roller

0001-0962

- 1) Remove the resin E-ring [1], and detach the stopper lever [2]; then, pull out the pickup roller support plate [3].

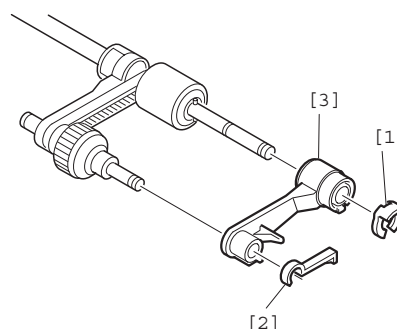

F-4-48

- 2) Remove the pin [4], and detach the separation roller [5].

- 3) Remove the pickup roller [6].

⚠ The pin [4] will come off as you remove the pickup roller; take care not to misplace it.

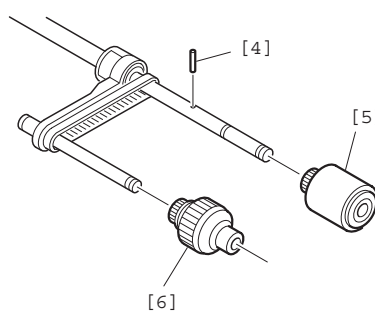

F-4-49

## 4.3.3 Separation Plate/Separation Pad

### 4.3.3.1 Removing the Separation Plate and the Separation Pad

0001-0972

- 1) Open the feeder cover.
- 2) Remove the 2 screws [1], and detach the separation plate [2] and the separation pad [3].

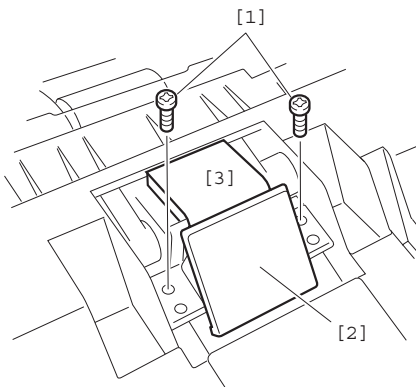

F-4-50

3) Slide the separation pad [3] as shown to detach.

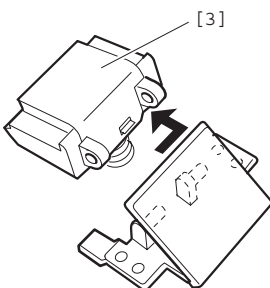

F-4-51

### 4.3.3.2 Adjusting the Separation Pressure [0001-0976](#)

1) Detach the pressure spring [1] and the spring base [2] found behind the separation pad [3] from the pad.

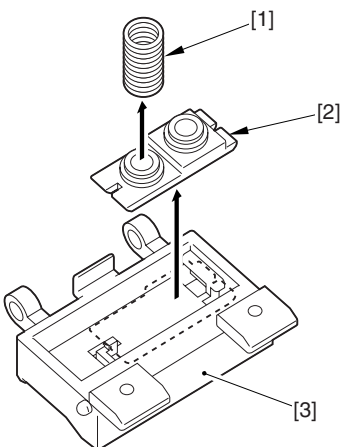

F-4-52

2) Change the orientation of the spring base [2], and attach it to the back of the separation pad.

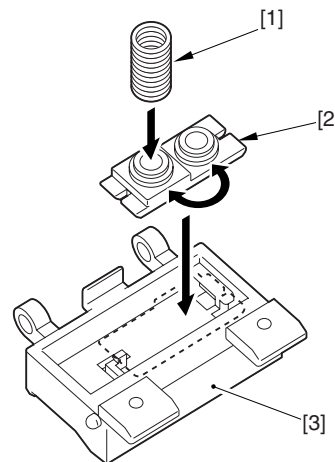

F-4-53

3) Attach the pressure spring [1] to the protrusion found at the center of the spring base [2]. You can set the separation pressure to either of 2 settings, determined by the height of the pressure spring [1] on the spring base [2].

## 4.3.4 Upper Registration Roller

### 4.3.4.1 Removing the Front Cover [0002-0360](#)

1) Open the feeder cover [1], and remove the screw [2].

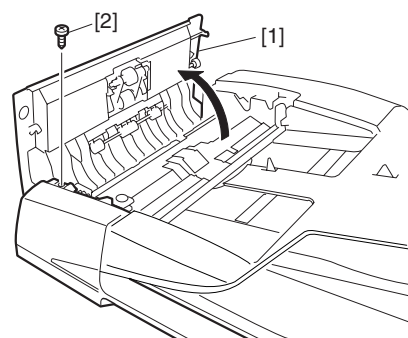

F-4-54

2) Remove the 2 screws [3], and detach the front cover [4].

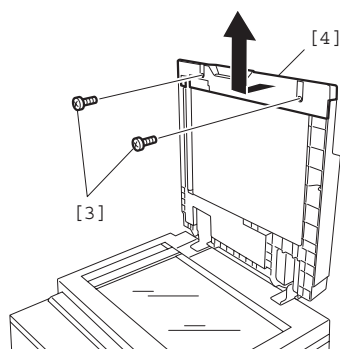

F-4-55

#### 4.3.4.2 Removing the Feeder

Cover

0001-0987

- 1) Remove the screw [1] and the positioning pin [2]; then, detach the feeder cover [3].

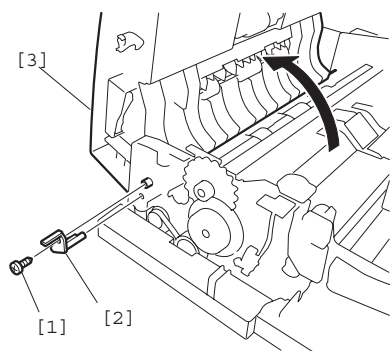

F-4-56

#### 4.3.4.3 Removing the Upper Registration Roller

0001-0989

- 1) Remove the 4 screws [1], and detach the open/close guide [2].

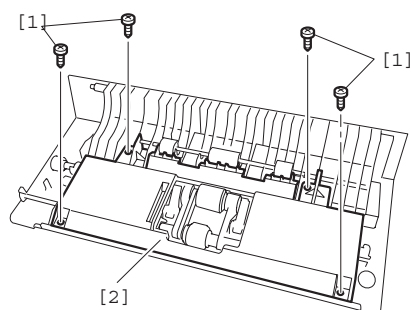

F-4-57

- 2) Slide out the shaft [3] in the direction indicated in the figure; then, detach the upper registration roller [4].

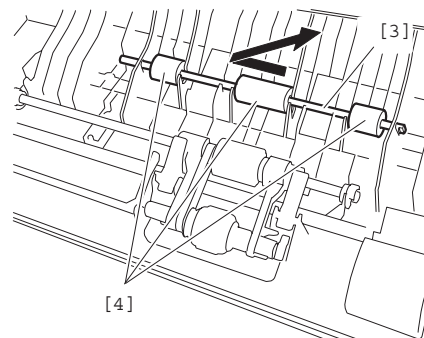

F-4-58

#### 4.3.5 Lower Registration Roller

##### 4.3.5.1 Removing the Rear

Cover

0002-0361

- 1) Open the feeder cover and the original pickup tray; then, move the screw [1].

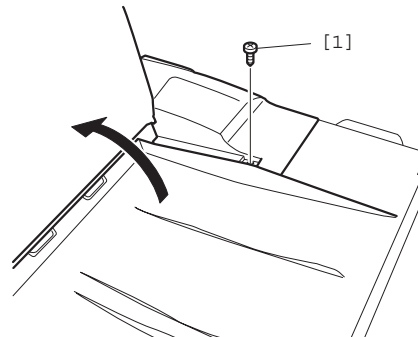

F-4-59

- 2) Remove the 2 screws [2], and detach the rear cover [3].

▲ Be sure to detach the cover while feeding the 3 claws [4] of the rear cover.



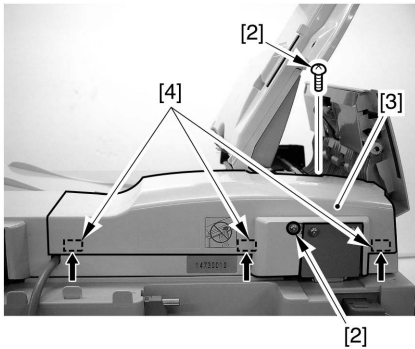

F-4-60

### 4.3.5.2 Removing the Front Cover

0002-0362

- 1) Open the feeder cover [1], and remove the screw [2].

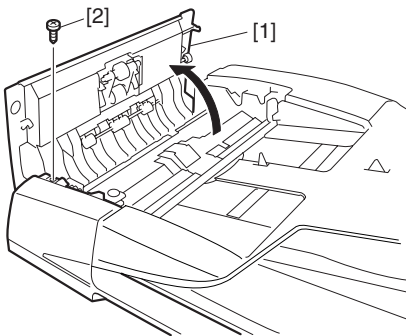

F-4-61

- 2) Remove the 2 screws [3], and detach the front cover [4].

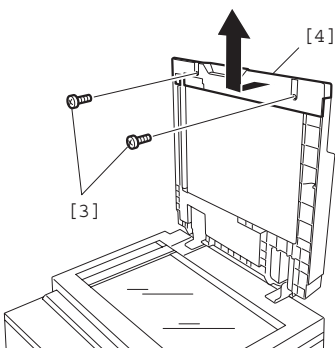

F-4-62

### 4.3.5.3 Removing the Feeder

Cover

0002-0363

- 1) Remove the screw [1] and the positioning pin [2]; then, detach the feeder cover [3].

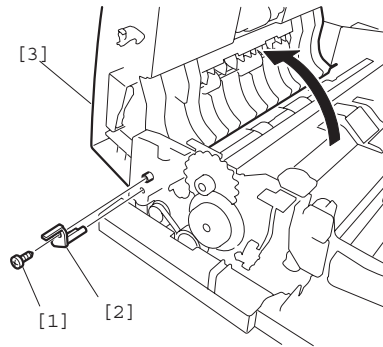

F-4-63

### 4.3.5.4 Removing the Pickup

Motor

0002-0364

- 1) Disconnect the connector [1].
- 2) Remove the 2 fixing screws [2] of the adjusting plate.

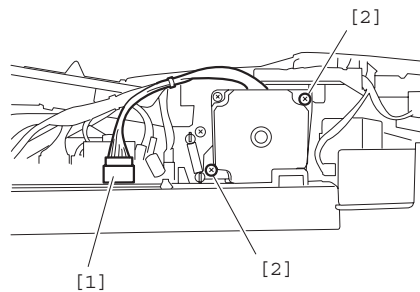

F-4-64

- 3) Remove the tension spring [3] using tweezers; then, remove the stepped screw [4], and detach the pickup motor [5] together with the adjusting plate.

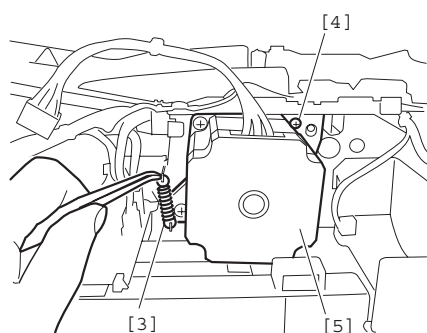

F-4-65

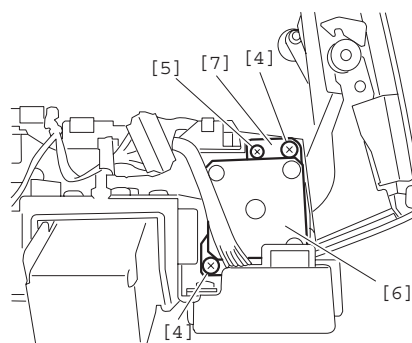

F-4-68

#### 4.3.5.5 Removing the Feed Motor

0002-0365

- 1) Free the 4 claws [1] of the harness guide; then, disconnect the connector [2].

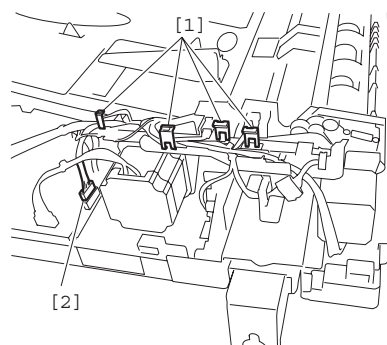

F-4-66

- 2) Remove the tension spring [3].

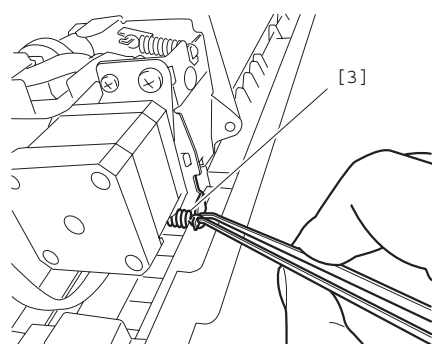

F-4-67

- 3) Remove the 2 screws [4] and the stepped screw [5]; then, detach the feed motor [6] together with the adjusting plate [7].

#### 4.3.5.6 Disassembling the Drive System

0002-1300

- 1) Disconnect the 2 connectors [1], and remove the screw [2] and the grounding fixing screw [3]; then, slide the harness guide slightly to the left, and lift it.

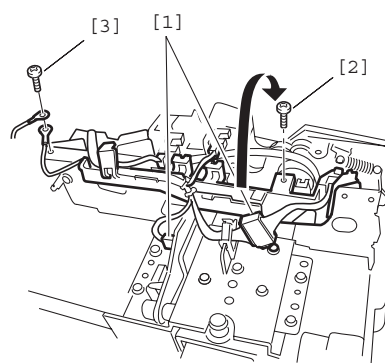

F-4-69

- 2) Remove the 4 screws [4] and the other screw [5]; then, detach the left hinge unit.

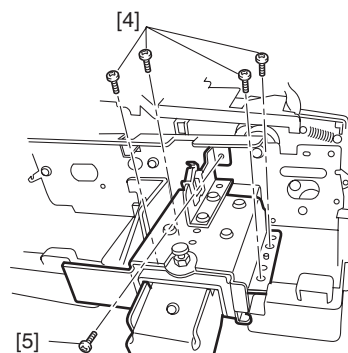

F-4-70

- 3) Remove the 3 screws [6] and the 2 other screws [7]; then, detach the motor base [8].

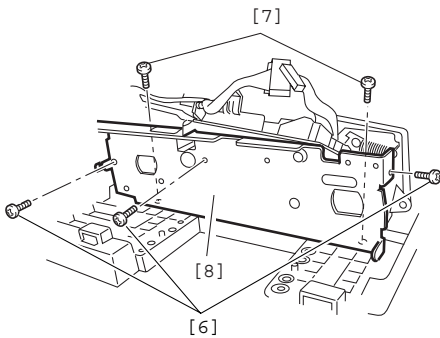

F-4-71

- 4) Detach the motor drive timing belt [9] [10].

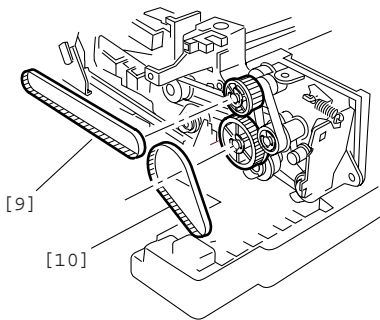

F-4-72

- 5) Remove the 3 E-rings [11], and detach the 2 pulleys [12], one-way clutch [13], and timing belt [14] [15].

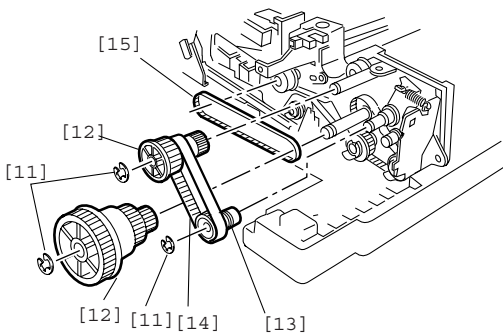

F-4-73

- 6) Remove the resin E-ring [16], and detach the pulley [17] and the timing belt [18]. You will have to remove the feeder unit when detaching the pulley [19].

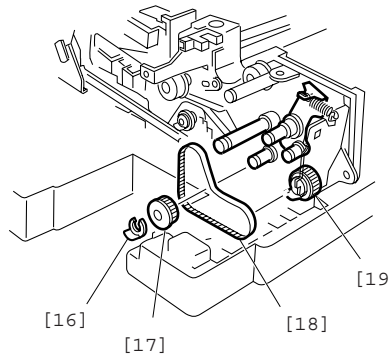

F-4-74

- ⚠** When attaching the timing belt [1], loosen the screw [21] of the tension arm [20]; then, force the arm counterclockwise to attach it. When you have attached the timing belt, tighten the screw [21].

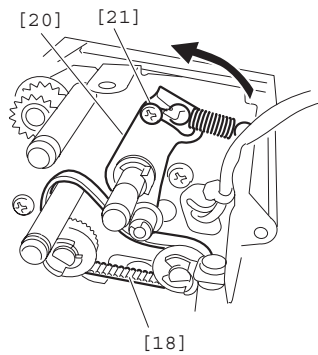

F-4-75

#### 4.3.5.7 Removing the Feeder Unit

0001-0992

- 1) Remove the screw [1], and pull out the busing [2]; then, detach the original pickup tray [3].

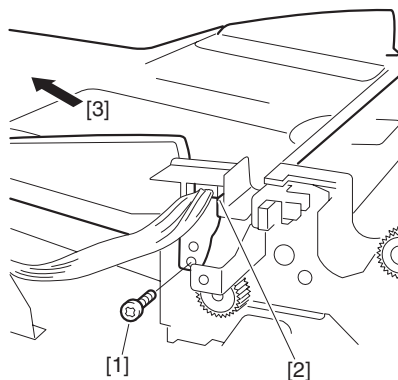

F-4-76

- 2) Remove the 2 screws [4] on the front cover side; then, remove the locking support [5], and disconnect the connector [6].

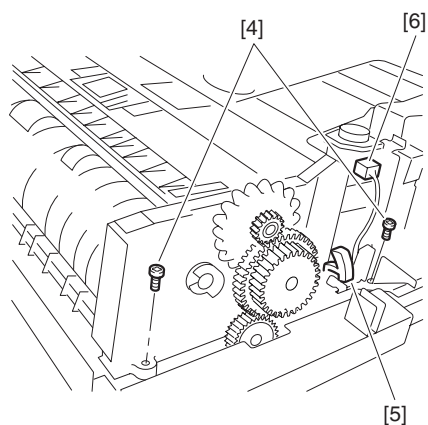

F-4-77

- 3) Disconnect the sensor connector [7].
- 4) Remove the 2 screws [7], and detach the feeder unit [89].

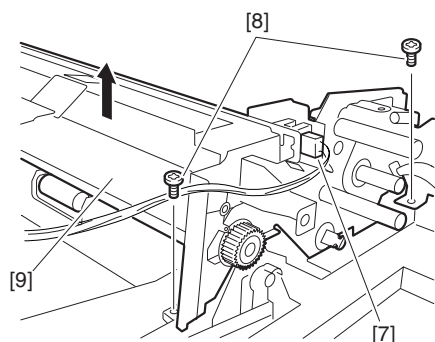

F-4-78

#### 4.3.5.8 Removing the Upper Delivery Reversing Roller 0001-1003

- 1) Turn over the feeder unit; then, remove the resin E-ring [1], and pull out the pulley [2] and the bushing [3].

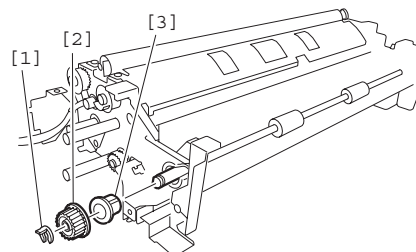

F-4-79

- 2) Remove the resin E-ring [4], and detach the bushing [5].
- 3) Remove the upper reversing delivery roller [6] and the separation guide [7].

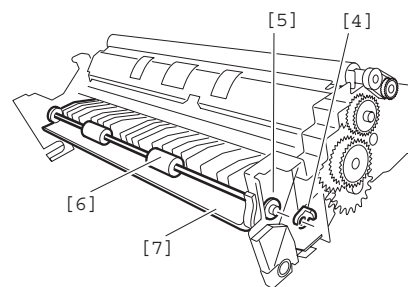

F-4-80

#### 4.3.5.9 Removing the Platen Guide L 0002-0554

- 1) Remove the 2 screws [1], and detach the platen guide L [2].

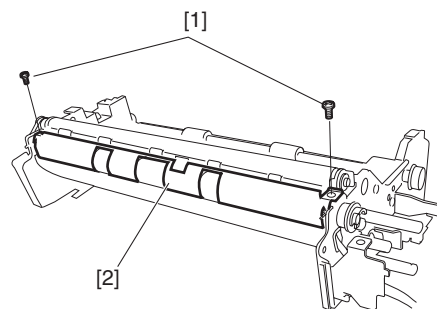

F-4-81

### 4.3.5.10 Removing the Read

#### Roller 1

0001-1019

- 1) Remove the resin E-ring [1], and detach the pulley [2], timing belt [3], and bushing [4].

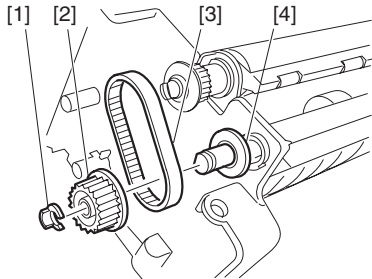

F-4-82

- 2) Remove the resin E-ring [5], and detach the pulley [6], and the bearing [7].

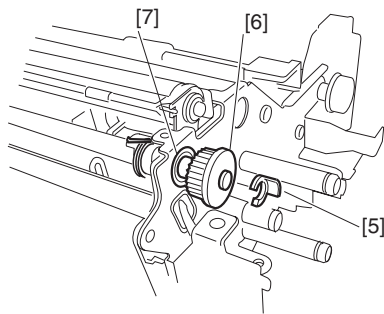

F-4-83

- 3) Remove the 2 resin E-rings [8], and detach the reader roller 1 [9] as shown in the figure.

⚠ Be sure to pull out the roller while keeping the sensor flag [1] out of the way.

⚠ The platen roller [10] will come off together with the arm when the read roller 1 [9] is removed; take care not to misplace the spring [11] of the arm.

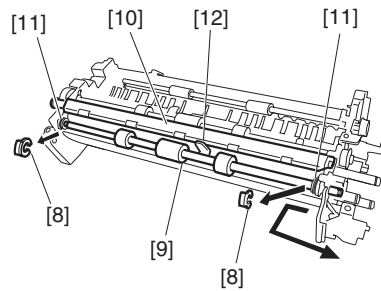

F-4-84

⚠ When mounting the platen roller pressure spring (left, right) [13], be sure that the hook segment of the spring is on the outside of the platen guide L.

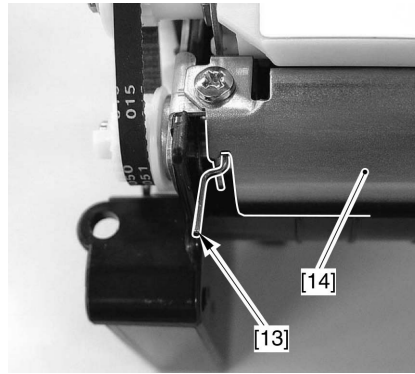

F-4-85

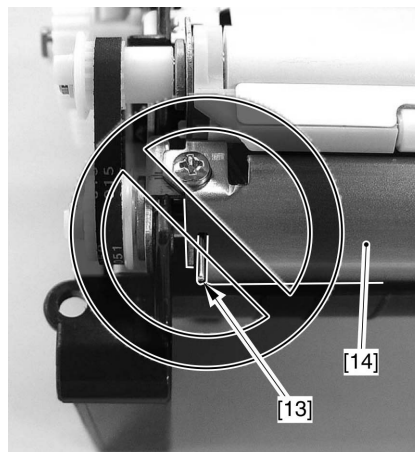

F-4-86

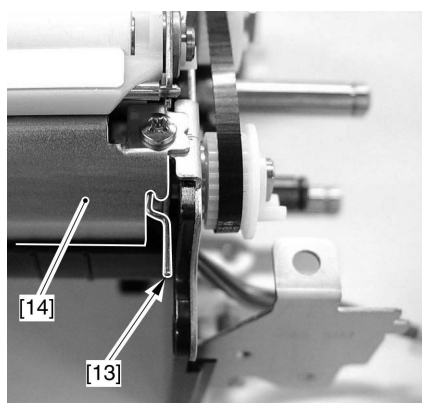

F-4-87

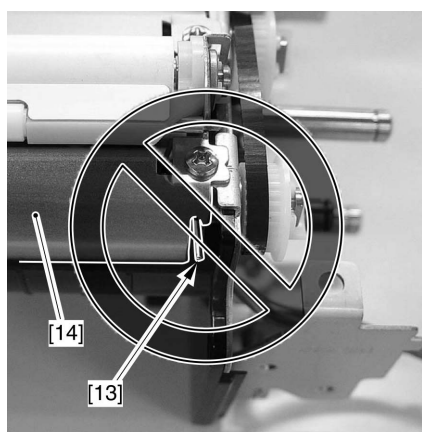

F-4-88

#### 4.3.5.11 Removing the Read Roller 2

0001-1016

- 1) Remove the screw [1], and detach the platen guide R [2].

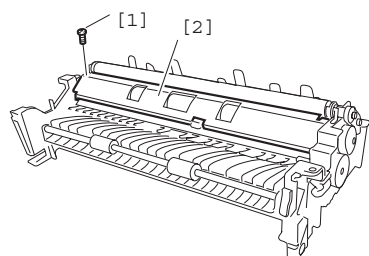

F-4-89

- 2) Remove the resin E-ring [3], and detach the pulley [4] and the bearing [5].

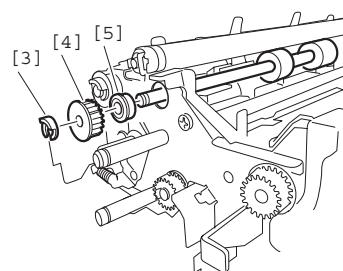

F-4-90

- 3) Remove the resin E-ring [6], gear [7], and bushing [8].
- 4) Lift the read roller 2 [9] along the space of the shaft opening as show; then, slide it to detach.

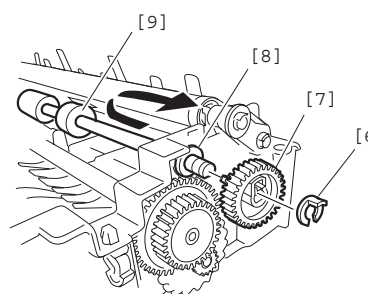

F-4-91

#### 4.3.5.12 Removing the Lower Registration Roller

0001-1051

- 1) Remove the 2 screws [1], and detach the sensor unit [2].

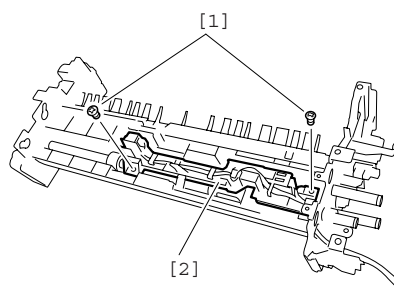

F-4-92

- 2) Remove the E-ring [3], and the resin E-ring [4], detach the bushing, remove the 3 screws [6]; then, detach the metal frame [7].

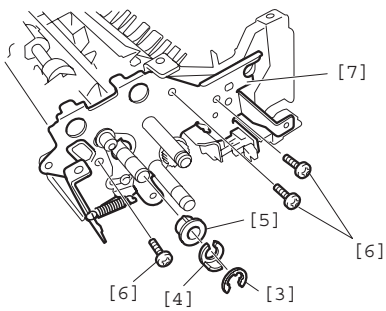

F-4-93

3) Remove the resin E-ring [8] and the bushing [9]; then, detach the lower registration roller [10].

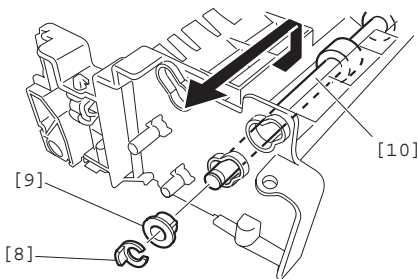

F-4-94

### 4.3.6 Delivery Reversing Roller (upper)

#### 4.3.6.1 Removing the Rear Cover

0002-0366

1) Open the feeder cover and the original pickup tray; then, move the screw [1].

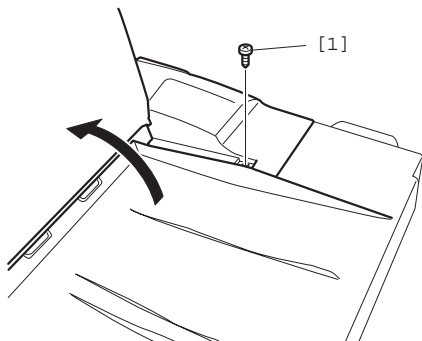

F-4-95

2) Remove the 2 screws [2], and detach the rear cover

[3].

⚠ Be sure to detach the cover while feeding the 3 claws [4] of the rear cover.

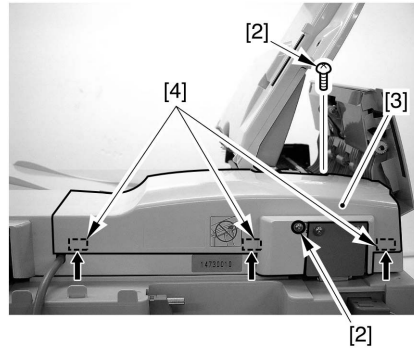

F-4-96

#### 4.3.6.2 Removing the Front Cover

0002-0367

1) Open the feeder cover [1], and remove the screw [2].

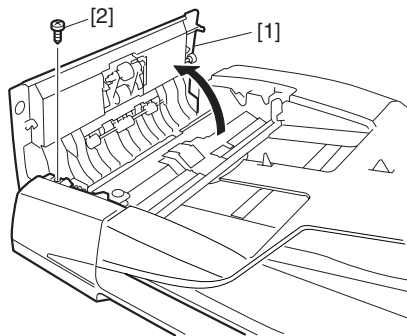

F-4-97

2) Remove the 2 screws [3], and detach the front cover [4].

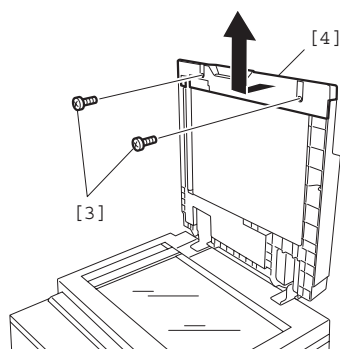

F-4-98

### 4.3.6.3 Removing the Feeder

#### Cover

0002-0368

- 1) Remove the screw [1] and the positioning pin [2]; then, detach the feeder cover [3].

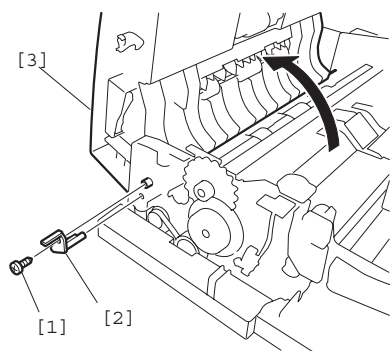

F-4-99

### 4.3.6.4 Removing the Pickup

#### Motor

0002-0369

- 1) Disconnect the connector [1].
- 2) Remove the 2 fixing screws [2] of the adjusting plate.

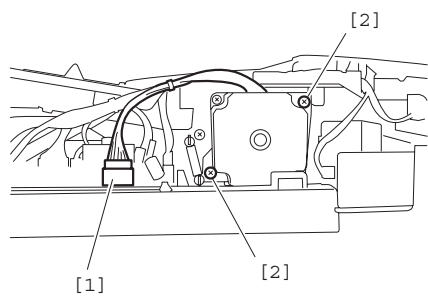

F-4-100

- 3) Remove the tension spring [3] using tweezers; then, remove the stepped screw [4], and detach the pickup motor [5] together with the adjusting plate.

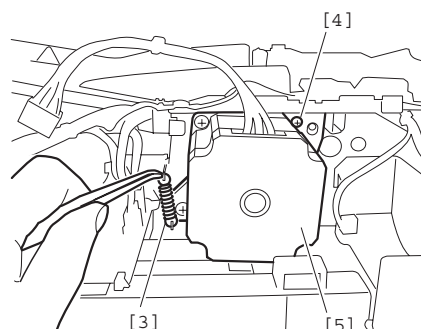

F-4-101

### 4.3.6.5 Removing the Feed

#### Motor

0002-0370

- 1) Free the 4 claws [1] of the harness guide; then, disconnect the connector [2].

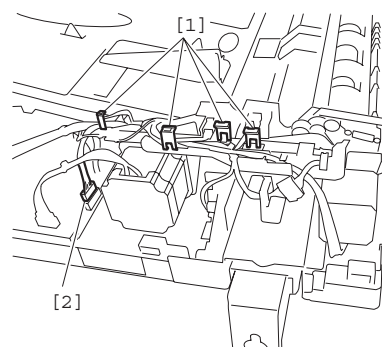

F-4-102

- 2) Remove the tension spring [3].

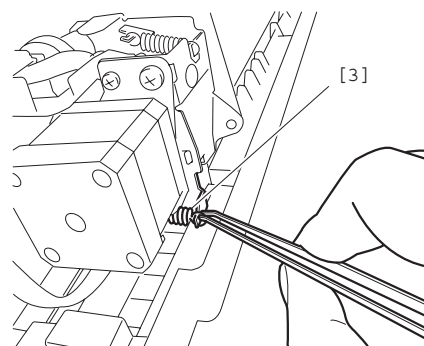

F-4-103



3) Remove the 2 screws [4] and the stepped screw [5]; then, detach the feed motor [6] together with the adjusting plate [7].

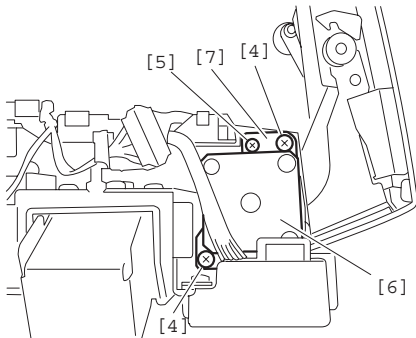

F-4-104

#### 4.3.6.6 Disassembling the Drive System

0002-1310

1) Disconnect the 2 connectors [1], and remove the screw [2] and the grounding fixing screw [3]; then, slide the harness guide slightly to the left, and lift it.

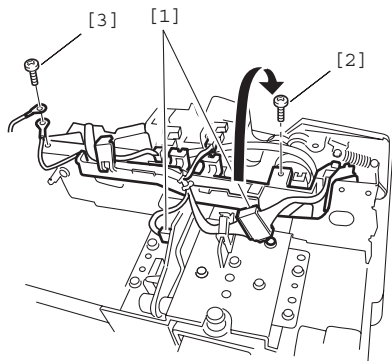

F-4-105

2) Remove the 4 screws [4] and the other screw [5]; then, detach the left hinge unit.

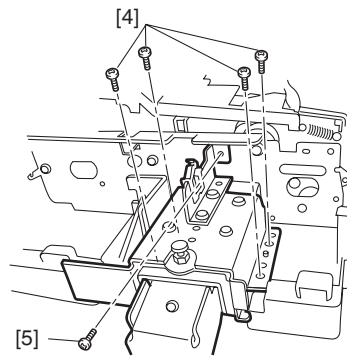

F-4-106

3) Remove the 3 screws [6] and the 2 other screws [7]; then, detach the motor base [8].

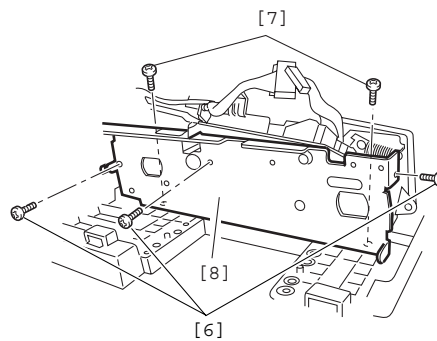

F-4-107

4) Detach the motor drive timing belt [9] [10].

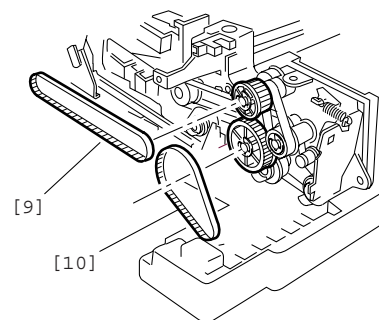

F-4-108

5) Remove the 3 E-rings [11], and detach the 2 pulleys [12], one-way clutch [13], and timing belt [14] [15].

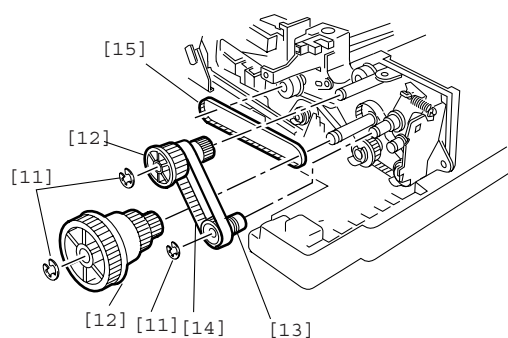

F-4-109

- 6) Remove the resin E-ring [16], and detach the pulley [17] and the timing belt [18]. You will have to remove the feeder unit when detaching the pulley [19].

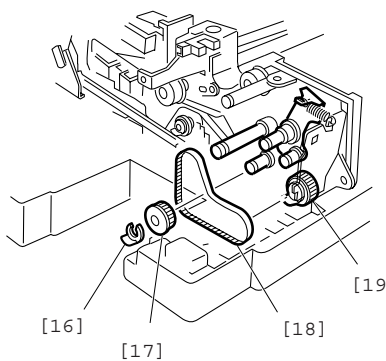

F-4-110

- ⚠** When attaching the timing belt [1], loosen the screw [21] of the tension arm [20]; then, force the arm counterclockwise to attach it. When you have attached the timing belt, tighten the screw [21].

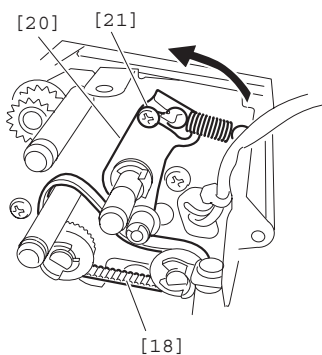

F-4-111

### 4.3.6.7 Removing the Feeder Unit

Unit

0001-1062

- 1) Remove the screw [1], and pull out the busing [2]; then, detach the original pickup tray [3].

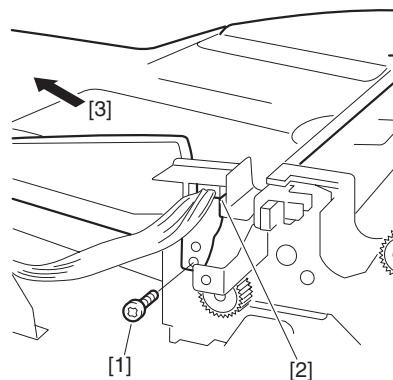

F-4-112

- 2) Remove the 2 screws [4] on the front cover side; then, remove the locking support [5], and disconnect the connector [6].

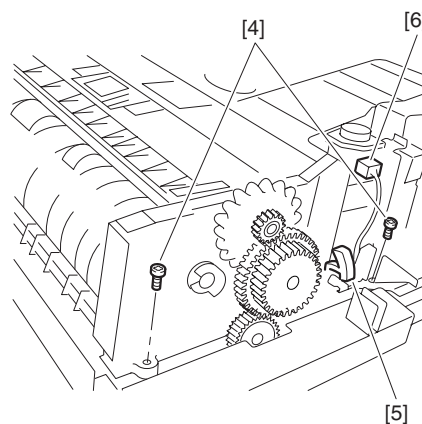

F-4-113

- 3) Disconnect the sensor connector [7].  
4) Remove the 2 screws [7], and detach the feeder unit [89].

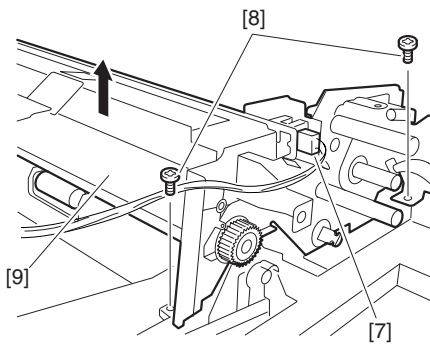

F-4-114

#### 4.3.6.8 Removing the Upper Delivery Reversing Roller 0001-1065

- 1) Turn over the feeder unit; then, remove the resin E-ring [1], and pull out the pulley [2] and the bushing [3].

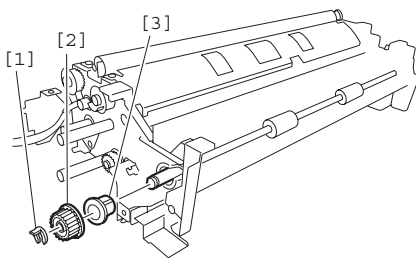

F-4-115

- 2) Remove the resin E-ring [4], and detach the bushing [5].
- 3) Remove the upper reversing delivery roller [6] and the separation guide [7].

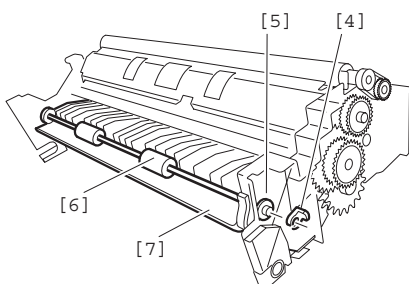

F-4-116

### 4.3.7 Read Roller 1

#### 4.3.7.1 Removing the Front Cover 0002-1312

- 1) Open the feeder cover [1], and remove the screw [2].

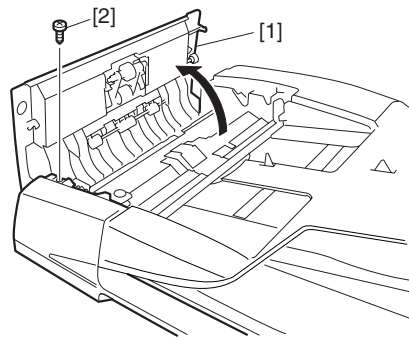

F-4-117

- 2) Remove the 2 screws [3], and detach the front cover [4].

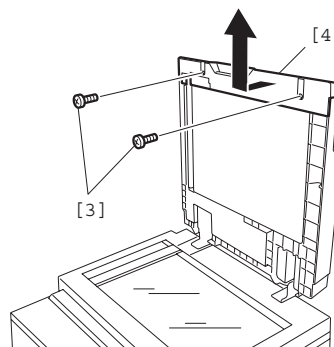

F-4-118

#### 4.3.7.2 Removing the Rear Cover 0002-1313

- 1) Open the feeder cover and the original pickup tray; then, move the screw [1].

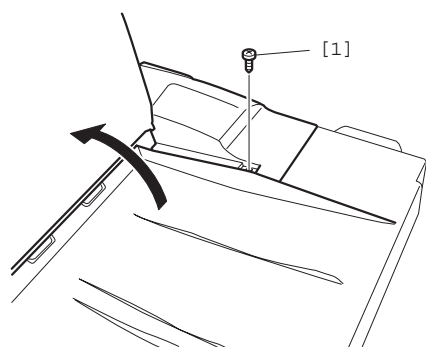

F-4-119

2) Remove the 2 screws [2], and detach the rear cover [3].

**⚠** Be sure to detach the cover while feeding the 3 claws [4] of the rear cover.

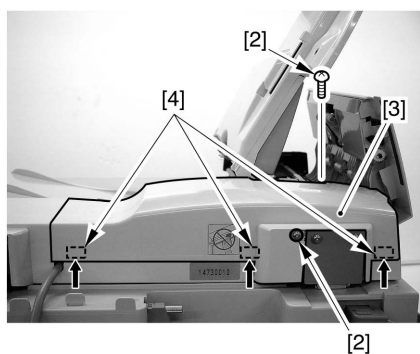

F-4-120

#### 4.3.7.3 Removing the Feeder Cover

0002-1316

1) Remove the screw [1] and the positioning pin [2]; then, detach the feeder cover [3].

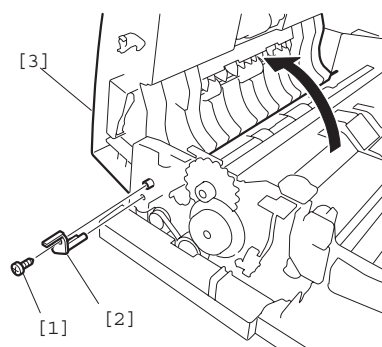

F-4-121

#### 4.3.7.4 Removing the Pickup Motor

0002-1325

1) Disconnect the connector [1].  
2) Remove the 2 fixing screws [2] of the adjusting plate.

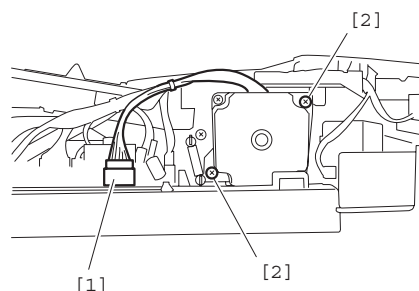

F-4-122

3) Remove the tension spring [3] using tweezers; then, remove the stepped screw [4], and detach the pickup motor [5] together with the adjusting plate.

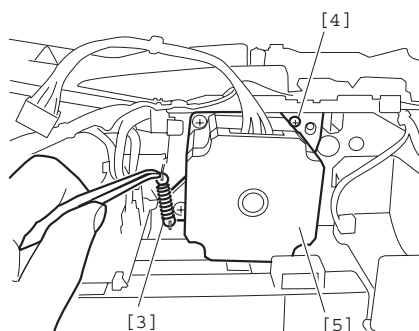

F-4-123

### 4.3.7.5 Removing the Feed Motor

0002-1326

- 1) Free the 4 claws [1] of the harness guide; then, disconnect the connector [2].

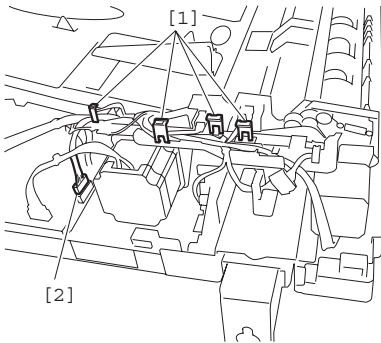

F-4-124

- 2) Remove the tension spring [3].

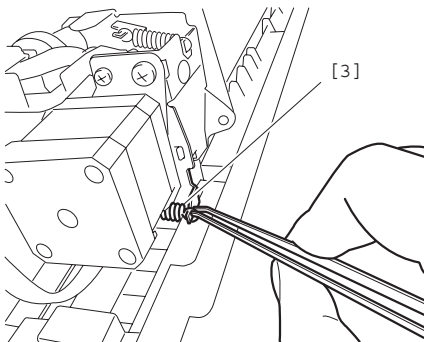

F-4-125

- 3) Remove the 2 screws [4] and the stepped screw [5]; then, detach the feed motor [6] together with the adjusting plate [7].

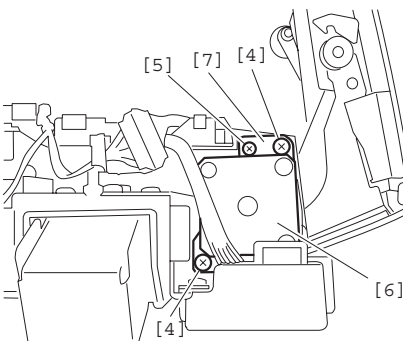

F-4-126

### 4.3.7.6 Disassembling the Drive System

0002-1327

- 1) Disconnect the 2 connectors [1], and remove the screw [2] and the grounding fixing screw [3]; then, slide the harness guide slightly to the left, and lift it.

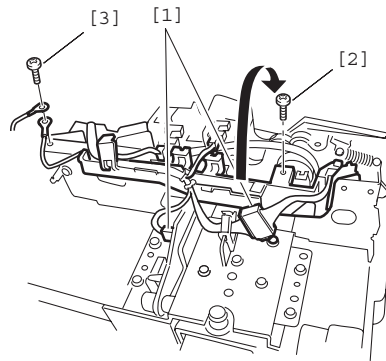

F-4-127

- 2) Remove the 4 screws [4] and the other screw [5]; then, detach the left hinge unit.

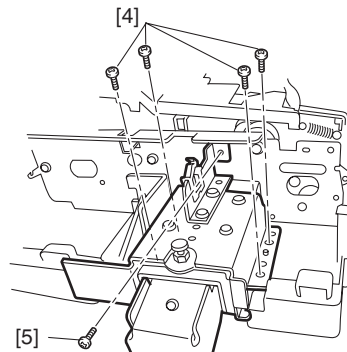

F-4-128

- 3) Remove the 3 screws [6] and the 2 other screws [7]; then, detach the motor base [8].

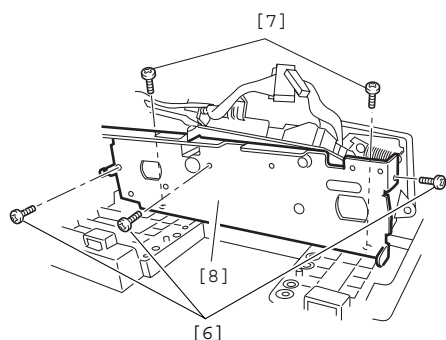

F-4-129

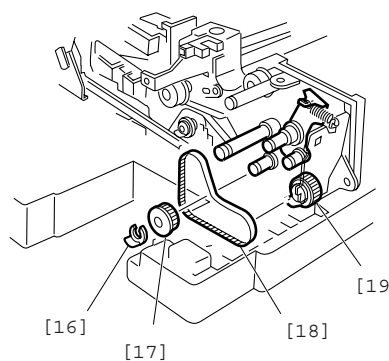

F-4-132

4) Detach the motor drive timing belt [9] [10].

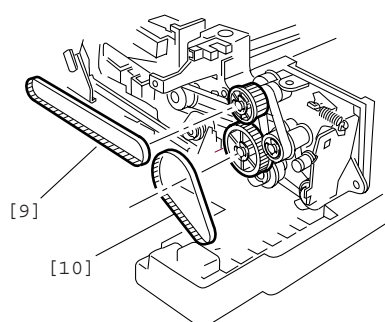

F-4-130

5) Remove the 3 E-rings [11], and detach the 2 pulleys [12], one-way clutch [13], and timing belt [14] [15].

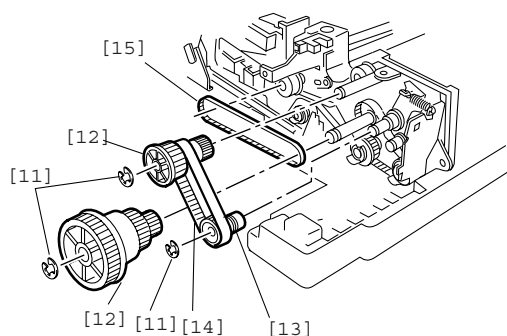

F-4-131

6) Remove the resin E-ring [16], and detach the pulley [17] and the timing belt [18]. You will have to remove the feeder unit when detaching the pulley [19].

⚠ When attaching the timing belt [1], loosen the screw [21] of the tension arm [20]; then, force the arm counterclockwise to attach it. When you have attached the timing belt, tighten the screw [21].

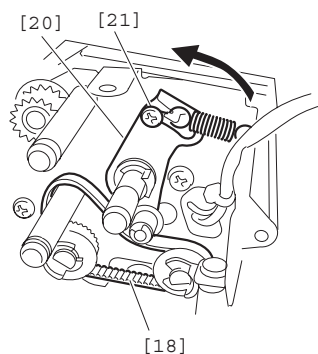

F-4-133

#### 4.3.7.7 Removing the Feeder Unit

0001-1068

1) Remove the screw [1], and pull out the busing [2]; then, detach the original pickup tray [3].

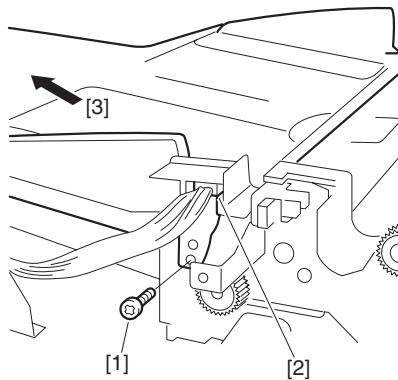

F-4-134

- 2) Remove the 2 screws [4] on the front cover side; then, remove the locking support [5], and disconnect the connector [6].

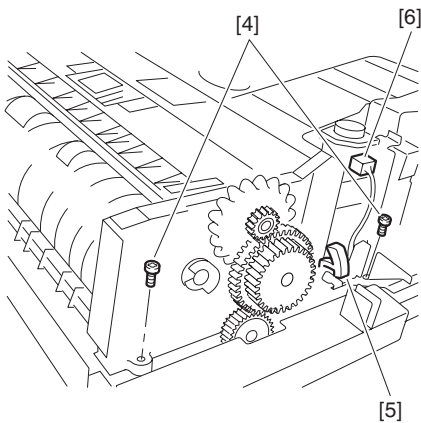

F-4-135

- 3) Disconnect the sensor connector [7].
- 4) Remove the 2 screws [7], and detach the feeder unit [89].

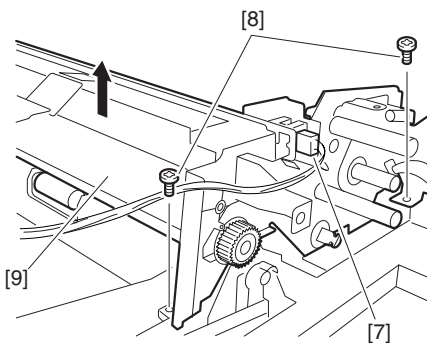

F-4-136

#### 4.3.7.8 Removing the Platen

Guide L

0002-0552

- 1) Remove the 2 screws [1], and detach the platen guide L [2].

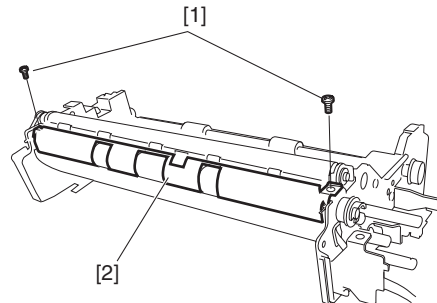

F-4-137

#### 4.3.7.9 Removing the Read

Roller 1

0001-1070

- 1) Remove the resin E-ring [1], and detach the pulley [2], timing belt [3], and bushing [4].

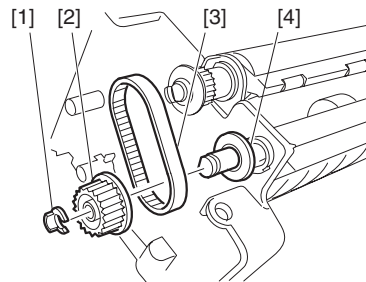

F-4-138

- 2) Remove the resin E-ring [5], and detach the pulley [6], and the bearing [7].

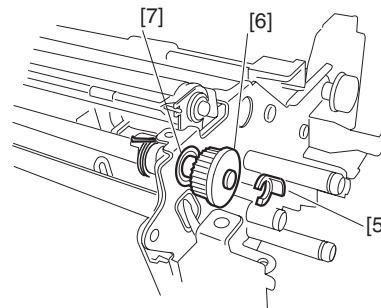

F-4-139

- 3) Remove the 2 resin E-rings [8], and detach the

reader roller 1 [9] as shown in the figure.

- ⚠ Be sure to pull out the roller while keeping the sensor flag [1] out of the way.
- ⚠ The platen roller [10] will come off together with the arm when the read roller 1 [9] is removed; take care not to misplace the spring [11] of the arm.

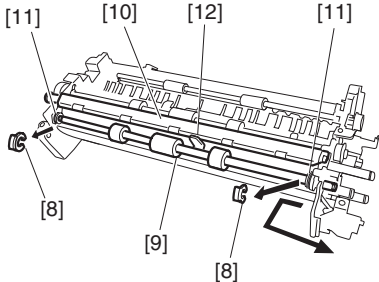

F-4-140

- ⚠ When mounting the platen roller pressure spring (left, right) [13], be sure that the hook segment of the spring is on the outside of the platen guide L.

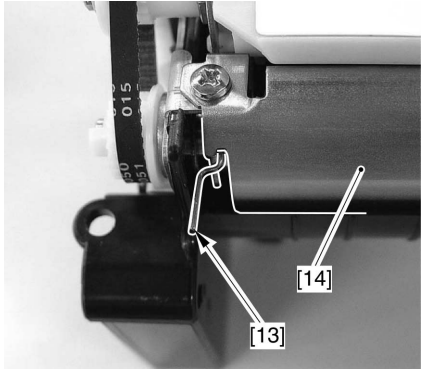

F-4-141

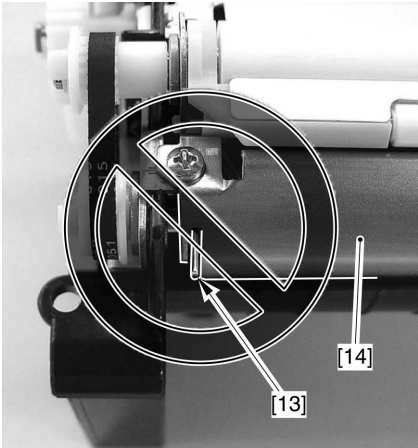

F-4-142

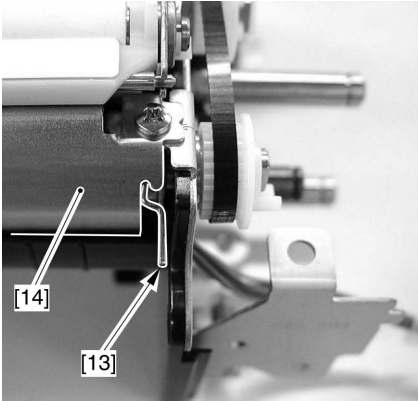

F-4-143

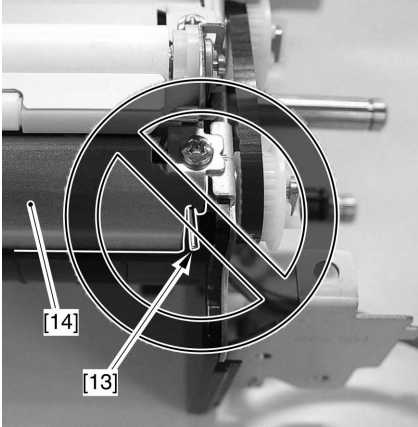

F-4-144



## 4.3.8 Read Roller 2

### 4.3.8.1 Removing the Front Cover

0002-1330

- 1) Open the feeder cover [1], and remove the screw [2].

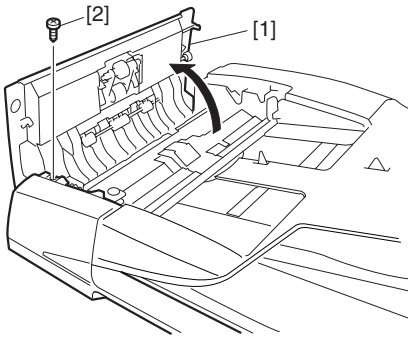

F-4-145

- 2) Remove the 2 screws [3], and detach the front cover [4].

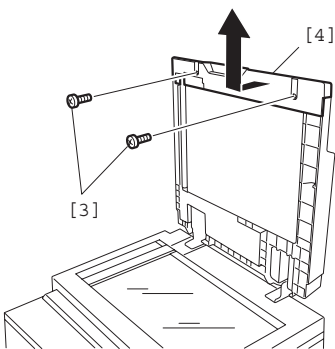

F-4-146

### 4.3.8.2 Removing the Rear Cover

0002-1331

- 1) Open the feeder cover and the original pickup tray; then, move the screw [1].

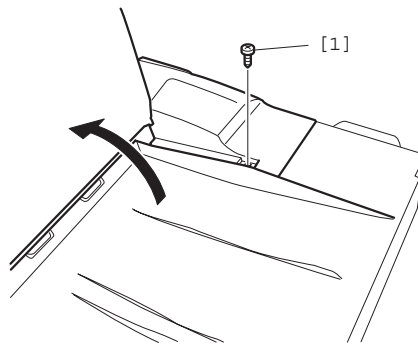

F-4-147

- 2) Remove the 2 screws [2], and detach the rear cover [3].

**⚠** Be sure to detach the cover while feeding the 3 claws [4] of the rear cover.

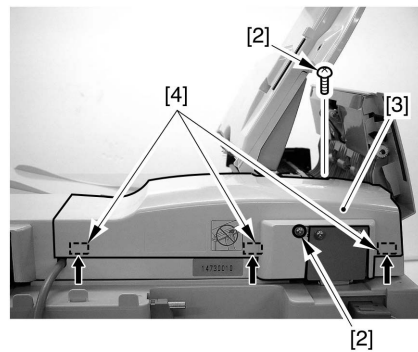

F-4-148

### 4.3.8.3 Removing the Feeder Cover

0002-1332

- 1) Remove the screw [1] and the positioning pin [2]; then, detach the feeder cover [3].

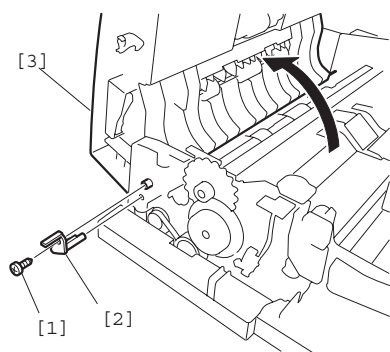

F-4-149

#### 4.3.8.4 Removing the Pickup

##### Motor

0002-1333

- 1) Disconnect the connector [1].
- 2) Remove the 2 fixing screws [2] of the adjusting plate.

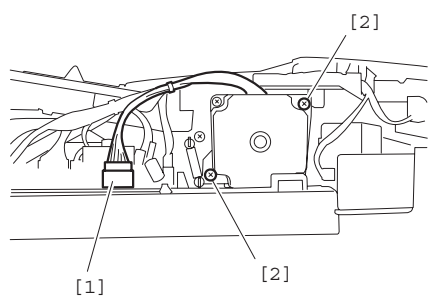

F-4-150

- 3) Remove the tension spring [3] using tweezers; then, remove the stepped screw [4], and detach the pickup motor [5] together with the adjusting plate.

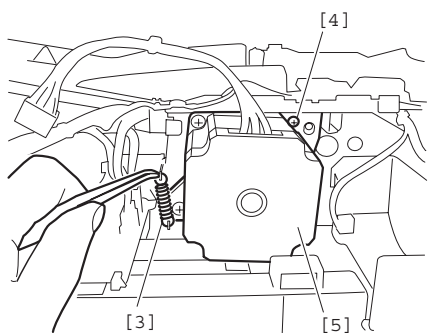

F-4-151

#### 4.3.8.5 Removing the Feed Motor

0002-1335

- 1) Free the 4 claws [1] of the harness guide; then, disconnect the connector [2].

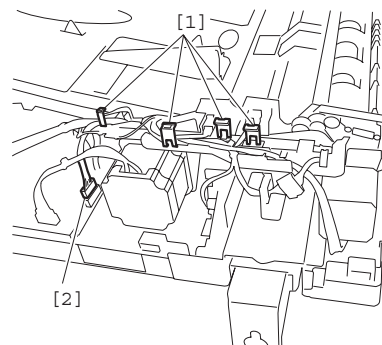

F-4-152

- 2) Remove the tension spring [3].

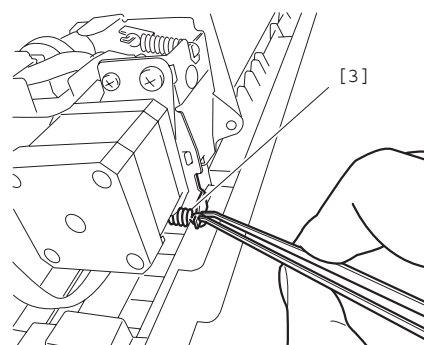

F-4-153

- 3) Remove the 2 screws [4] and the stepped screw [5]; then, detach the feed motor [6] together with the adjusting plate [7].

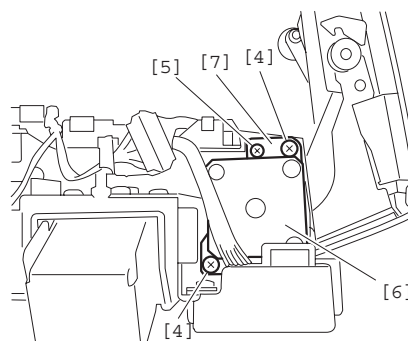

F-4-154

### 4.3.8.6 Disassembling the Drive System 0002-1336

- 1) Disconnect the 2 connectors [1], and remove the screw [2] and the grounding fixing screw [3]; then, slide the harness guide slightly to the left, and lift it.

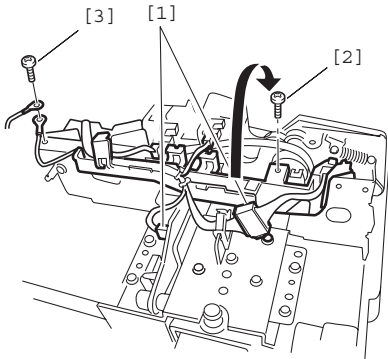

F-4-155

- 2) Remove the 4 screws [4] and the other screw [5]; then, detach the left hinge unit.

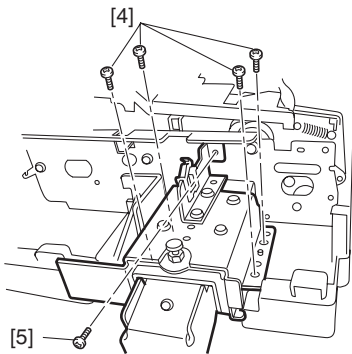

F-4-156

- 3) Remove the 3 screws [6] and the 2 other screws [7]; then, detach the motor base [8].

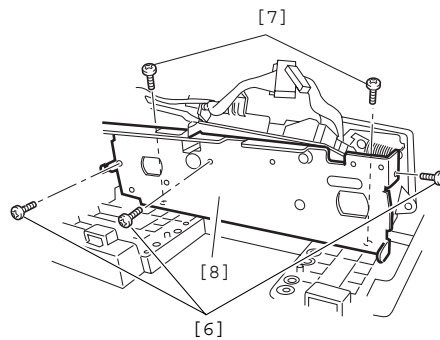

F-4-157

- 4) Detach the motor drive timing belt [9] [10].

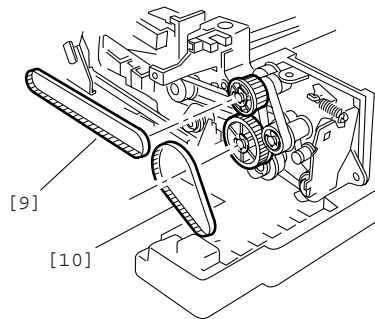

F-4-158

- 5) Remove the 3 E-rings [11], and detach the 2 pulleys [12], one-way clutch [13], and timing belt [14] [15].

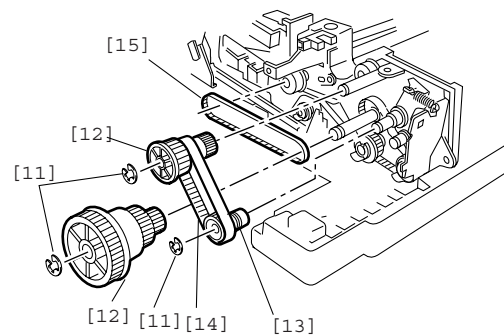

F-4-159

- 6) Remove the resin E-ring [16], and detach the pulley [17] and the timing belt [18]. You will have to remove the feeder unit when detaching the pulley [19].

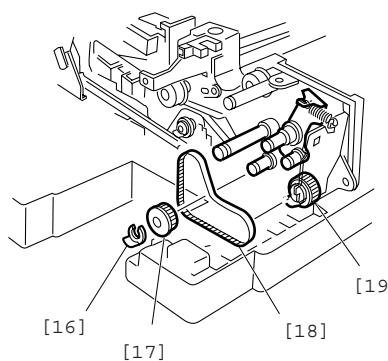

F-4-160

⚠ When attaching the timing belt [1], loosen the screw [21] of the tension arm [20]; then, force the arm counterclockwise to attach it. When you have attached the timing belt, tighten the screw [21].

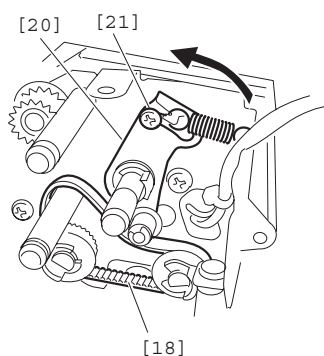

F-4-161

#### 4.3.8.7 Removing the Feeder Unit

0001-1071

1) Remove the screw [1], and pull out the busing [2]; then, detach the original pickup tray [3].

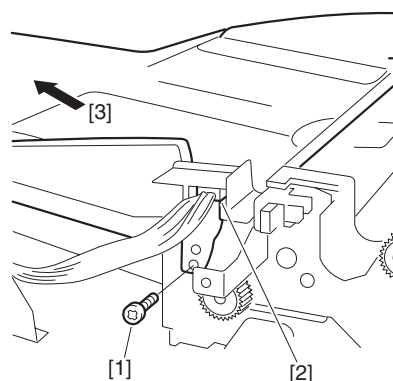

F-4-162

2) Remove the 2 screws [4] on the front cover side; then, remove the locking support [5], and disconnect the connector [6].

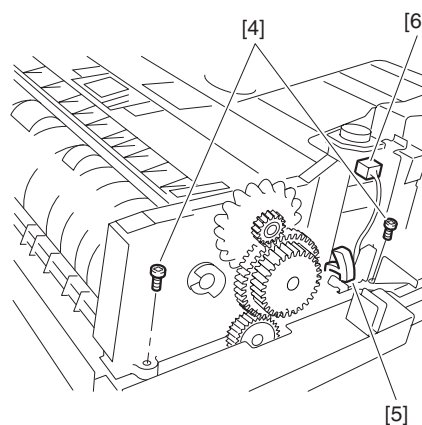

F-4-163

3) Disconnect the sensor connector [7].

4) Remove the 2 screws [7], and detach the feeder unit [8].

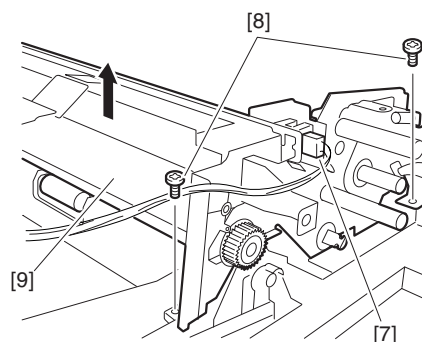

F-4-164

### 4.3.8.8 Removing the Read

#### Roller 2

0001-1074

- 1) Remove the screw [1], and detach the platen guide R [2].

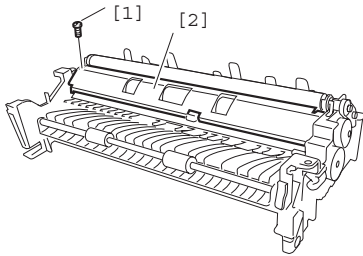

F-4-165

- 2) Remove the resin E-ring [3], and detach the pulley [4] and the bearing [5].

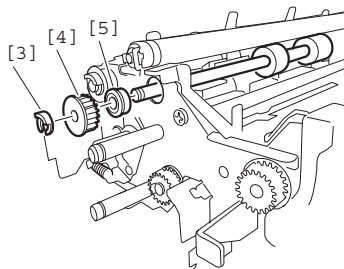

F-4-166

- 3) Remove the resin E-ring [6], gear [7], and bushing [8].
- 4) Lift the read roller 2 [9] along the space of the shaft opening as show; then, slide it to detach.

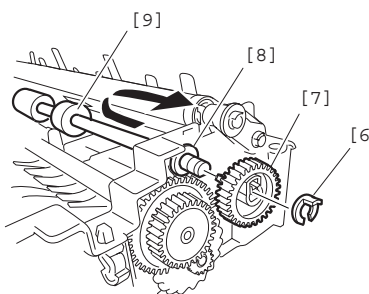

F-4-167

### 4.3.9 Platen Roller

#### 4.3.9.1 Removing the Front

##### Cover

0002-1364

- 1) Open the feeder cover [1], and remove the screw [2].

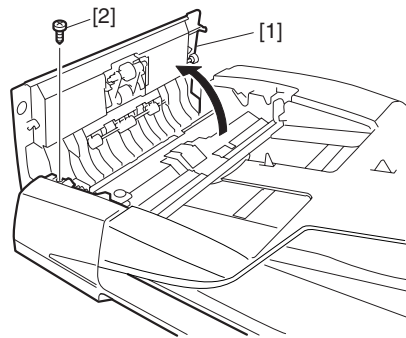

F-4-168

- 2) Remove the 2 screws [3], and detach the front cover [4].

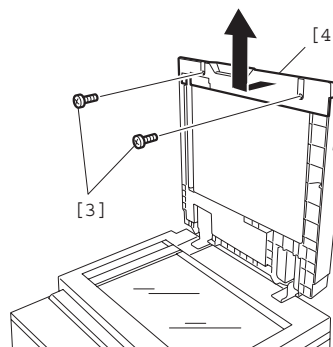

F-4-169

#### 4.3.9.2 Removing the Rear

##### Cover

0002-1367

- 1) Open the feeder cover and the original pickup tray; then, move the screw [1].

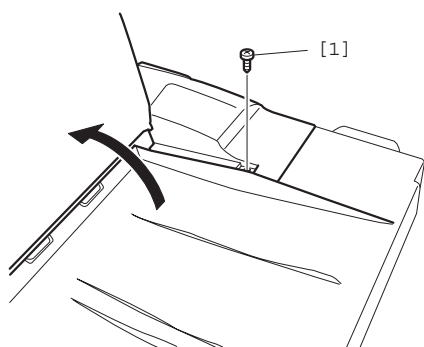

F-4-170

2) Remove the 2 screws [2], and detach the rear cover [3].

**⚠** Be sure to detach the cover while feeding the 3 claws [4] of the rear cover.

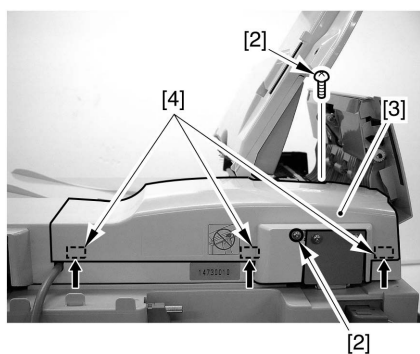

F-4-171

#### 4.3.9.3 Removing the Feeder Cover

0002-1368

1) Remove the screw [1] and the positioning pin [2]; then, detach the feeder cover [3].

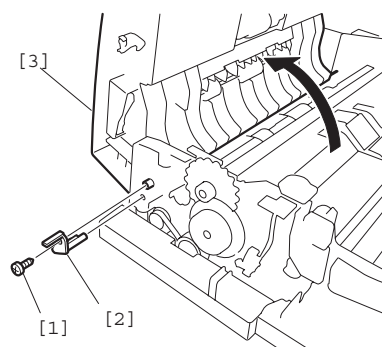

F-4-172

#### 4.3.9.4 Removing the Pickup Motor

0002-1370

1) Disconnect the connector [1].  
2) Remove the 2 fixing screws [2] of the adjusting plate.

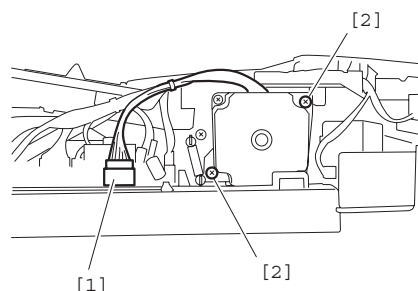

F-4-173

3) Remove the tension spring [3] using tweezers; then, remove the stepped screw [4], and detach the pickup motor [5] together with the adjusting plate.

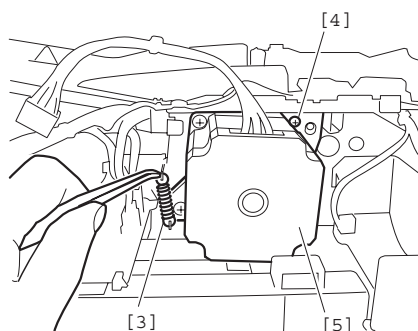

F-4-174

### 4.3.9.5 Removing the Feed Motor 0002-1371

1) Free the 4 claws [1] of the harness guide; then, disconnect the connector [2].

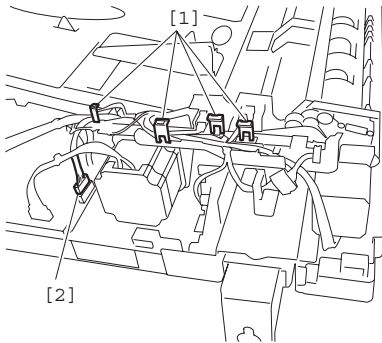

F-4-175

2) Remove the tension spring [3].

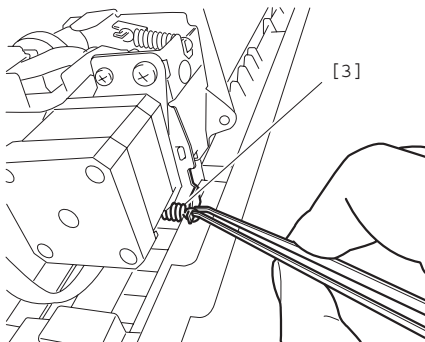

F-4-176

3) Remove the 2 screws [4] and the stepped screw [5]; then, detach the feed motor [6] together with the adjusting plate [7].

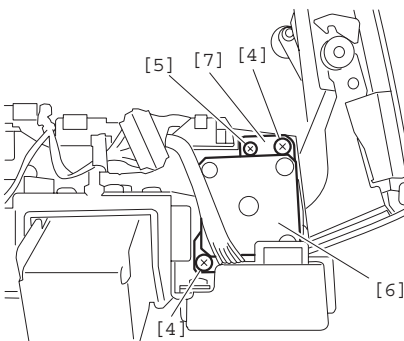

F-4-177

### 4.3.9.6 Disassembling the Drive System 0002-1374

1) Disconnect the 2 connectors [1], and remove the screw [2] and the grounding fixing screw [3]; then, slide the harness guide slightly to the left, and lift it.

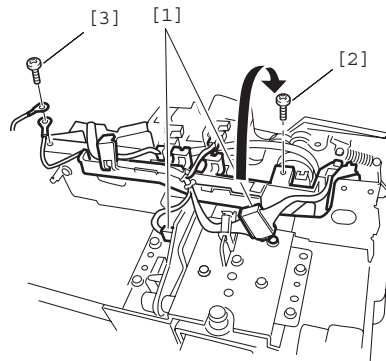

F-4-178

2) Remove the 4 screws [4] and the other screw [5]; then, detach the left hinge unit.

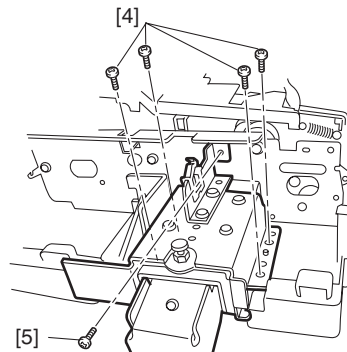

F-4-179

3) Remove the 3 screws [6] and the 2 other screws [7]; then, detach the motor base [8].

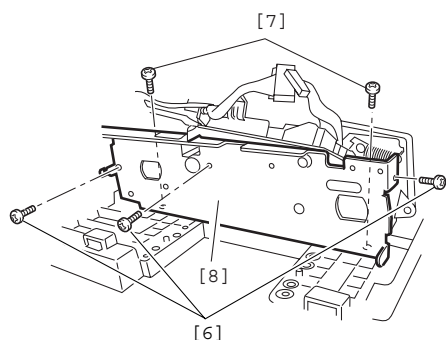

F-4-180

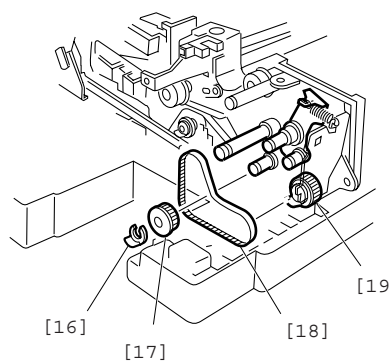

F-4-183

4) Detach the motor drive timing belt [9] [10].

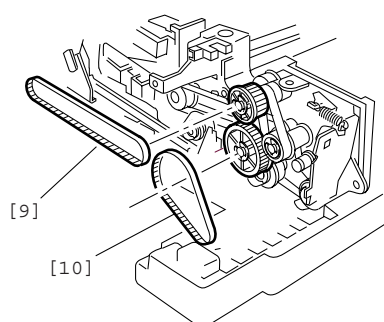

F-4-181

5) Remove the 3 E-rings [11], and detach the 2 pulleys [12], one-way clutch [13], and timing belt [14] [15].

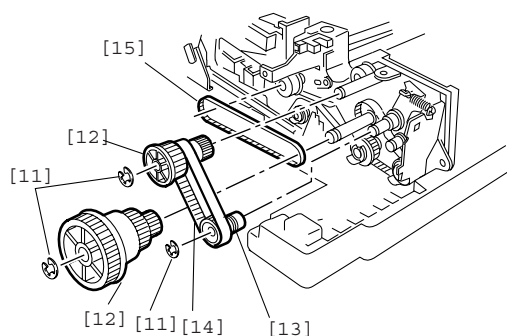

F-4-182

6) Remove the resin E-ring [16], and detach the pulley [17] and the timing belt [18]. You will have to remove the feeder unit when detaching the pulley [19].

⚠ When attaching the timing belt [1], loosen the screw [21] of the tension arm [20]; then, force the arm counterclockwise to attach it. When you have attached the timing belt, tighten the screw [21].

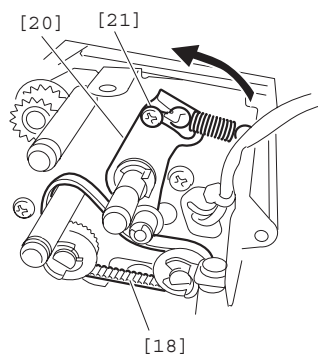

F-4-184

#### 4.3.9.7 Removing the Feeder Unit

0001-1076

1) Remove the screw [1], and pull out the busing [2]; then, detach the original pickup tray [3].



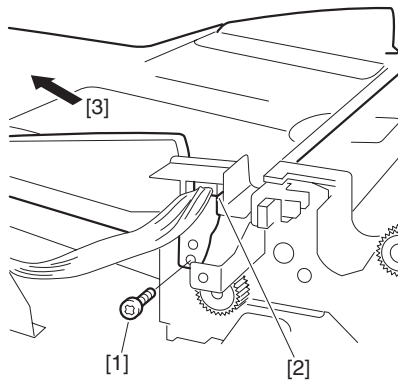

F-4-185

- 2) Remove the 2 screws [4] on the front cover side; then, remove the locking support [5], and disconnect the connector [6].

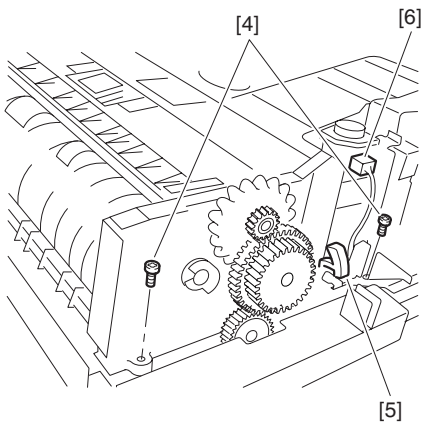

F-4-186

- 3) Disconnect the sensor connector [7].
- 4) Remove the 2 screws [7], and detach the feeder unit [89].

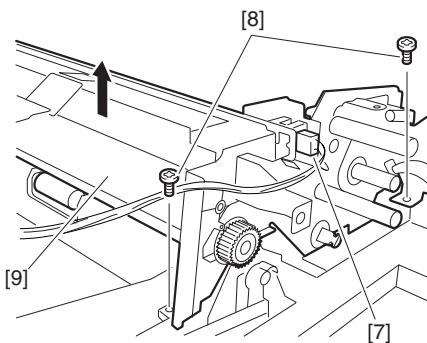

F-4-187

#### 4.3.9.8 Removing the Platen

##### Guide L

0002-0549

- 1) Remove the 2 screws [1], and detach the platen guide L [2].

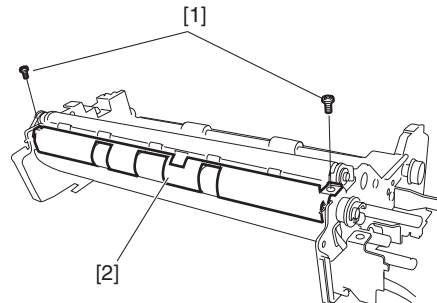

F-4-188

#### 4.3.9.9 Removing the Platen

##### Roller

0001-1078

- 1) Remove the resin E-ring [5]; then, detach the pulley [6], timing belt [7], and bushing [8].
- 2) Remove the resin E-ring [9], and detach the bushing [10].

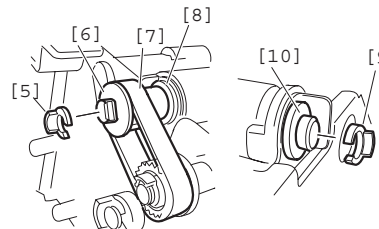

F-4-189

- 3) Detach the platen roller [11] as show together with the roller holder.

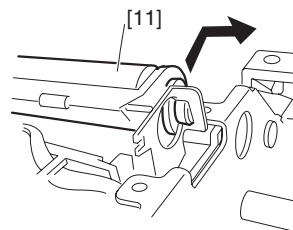

F-4-190

- 4) Detach the platen roller [11] from the roll holder.

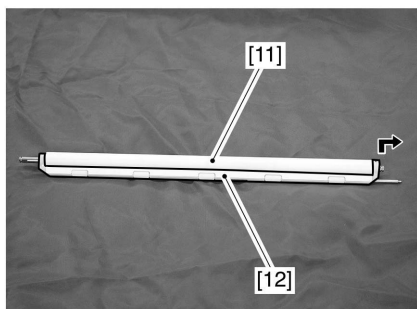

F-4-191

⚠ When mounting the platen roller [11], and the roll holder, be sure that the roll shaft [13] is fitted in the cut-off [14] of the base.

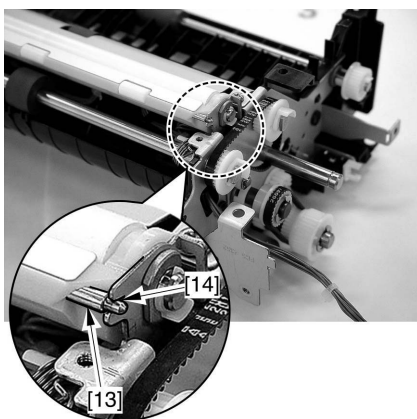

F-4-192

### 4.3.10 Delivery Reversing Roller (lower)

#### 4.3.10.1 Removing the Lower

Delivery Reversing Roller [0002-0577](#)

**If you are replacing the roller segment of the lower delivery reversing roller,**

- 1) Open the original pickup tray, and push up the roller segment [1] to detach.

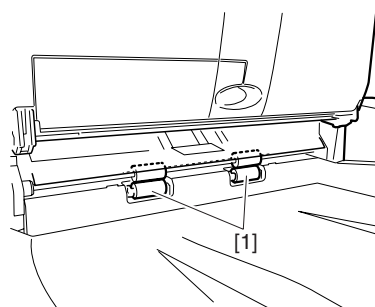

F-4-193

**If you must detach the whole of the lower delivery reversing roller, go through the following steps:**

#### 4.3.10.2 Removing the Rear Cover

[0002-0588](#)

- 1) Open the feeder cover and the original pickup tray; then, move the screw [1].

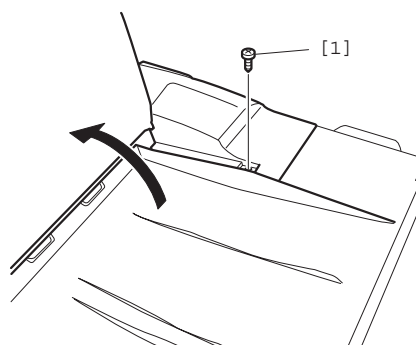

F-4-194

- 2) Remove the 2 screws [2], and detach the rear cover [3].

⚠ Be sure to detach the cover while feeding the 3 claws [4] of the rear cover.

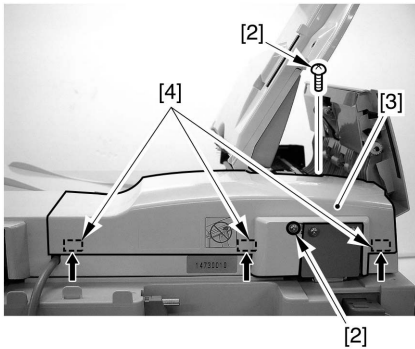

F-4-195

### 4.3.10.3 Removing the Front Cover

0002-0589

- 1) Open the feeder cover [1], and remove the screw [2].

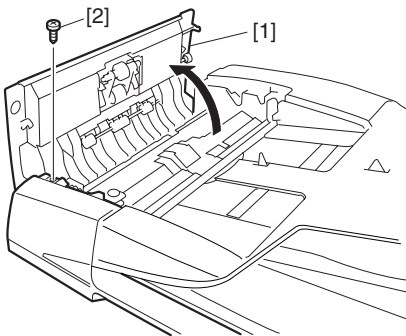

F-4-196

- 2) Remove the 2 screws [3], and detach the front cover [4].

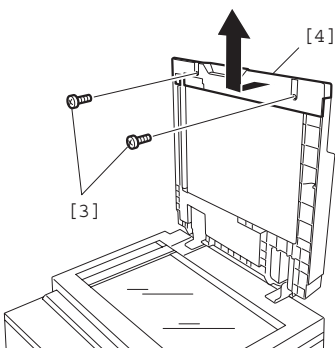

F-4-197

### 4.3.10.4 Removing the Feeder

Cover

0002-1388

- 1) Remove the screw [1] and the positioning pin [2]; then, detach the feeder cover [3].

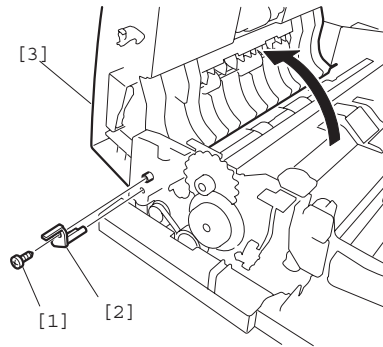

F-4-198

### 4.3.10.5 Removing the Pickup

Motor

0002-1389

- 1) Disconnect the connector [1].
- 2) Remove the 2 fixing screws [2] of the adjusting plate.

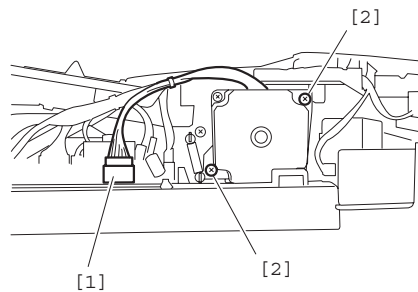

F-4-199

- 3) Remove the tension spring [3] using tweezers; then, remove the stepped screw [4], and detach the pickup motor [5] together with the adjusting plate.

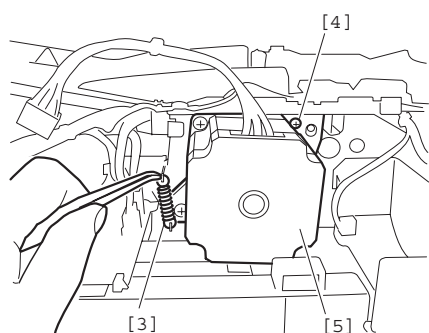

F-4-200

#### 4.3.10.6 Removing the Feed Motor

0002-1390

- 1) Free the 4 claws [1] of the harness guide; then, disconnect the connector [2].

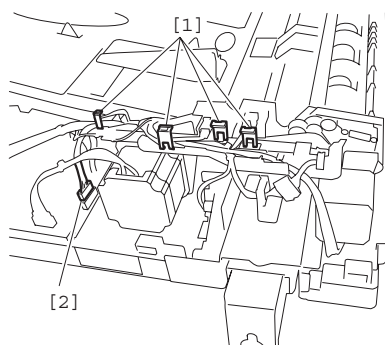

F-4-201

- 2) Remove the tension spring [3].

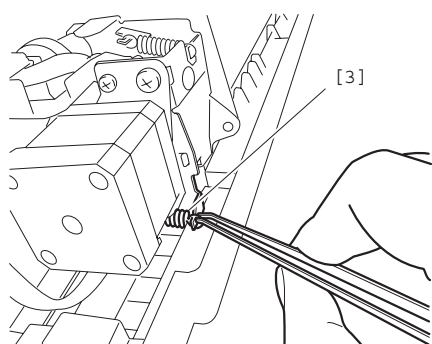

F-4-202

- 3) Remove the 2 screws [4] and the stepped screw [5]; then, detach the feed motor [6] together with the adjusting plate [7].

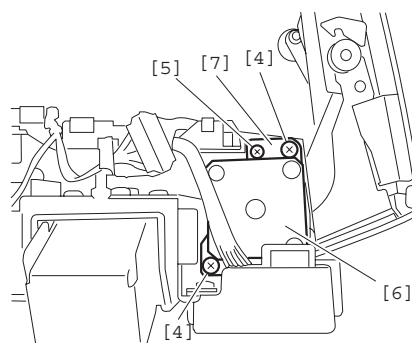

F-4-203

#### 4.3.10.7 Disassembling the Drive System

0002-1392

- 1) Disconnect the 2 connectors [1], and remove the screw [2] and the grounding fixing screw [3]; then, slide the harness guide slightly to the left, and lift it.

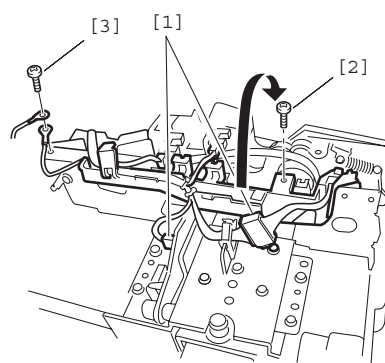

F-4-204

- 2) Remove the 4 screws [4] and the other screw [5]; then, detach the left hinge unit.

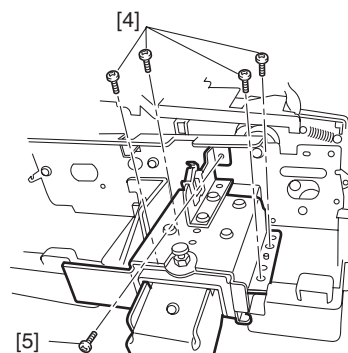

F-4-205

- 3) Remove the 3 screws [6] and the 2 other screws [7]; then, detach the motor base [8].

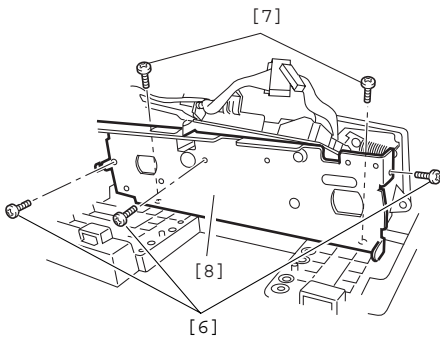

F-4-206

- 4) Detach the motor drive timing belt [9] [10].

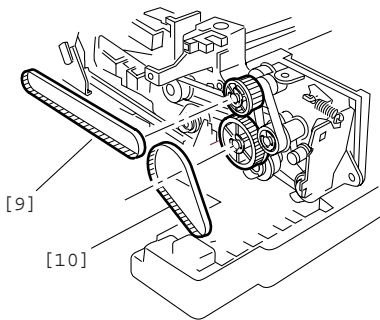

F-4-207

- 5) Remove the 3 E-rings [11], and detach the 2 pulleys [12], one-way clutch [13], and timing belt [14] [15].

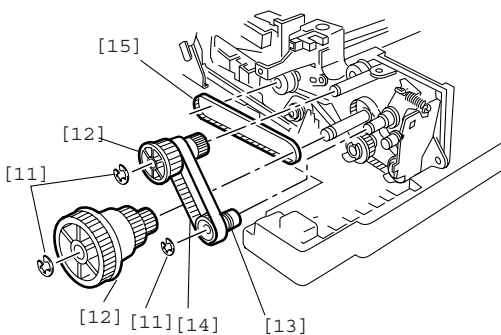

F-4-208

- 6) Remove the resin E-ring [16], and detach the pulley [17] and the timing belt [18]. You will have to remove the feeder unit when detaching the pulley [19].

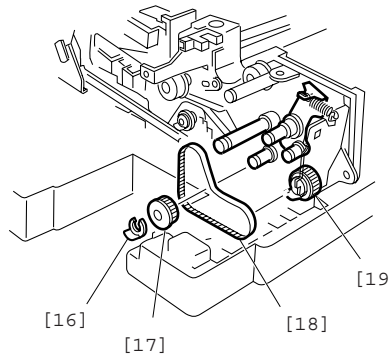

F-4-209

- ⚠** When attaching the timing belt [1], loosen the screw [21] of the tension arm [20]; then, force the arm counterclockwise to attach it. When you have attached the timing belt, tighten the screw [21].

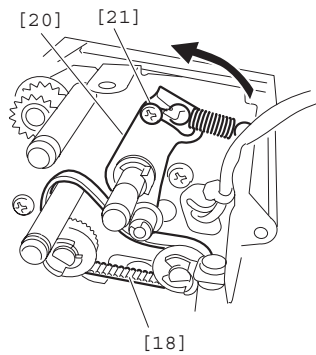

F-4-210

#### 4.3.10.8 Removing the Feeder Unit

0001-1100

- 1) Remove the screw [1], and pull out the busing [2]; then, detach the original pickup tray [3].

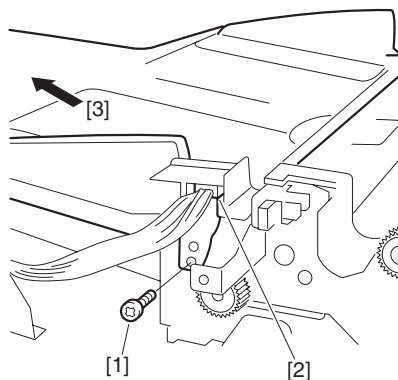

F-4-211

- 2) Remove the 2 screws [4] on the front cover side; then, remove the locking support [5], and disconnect the connector [6].

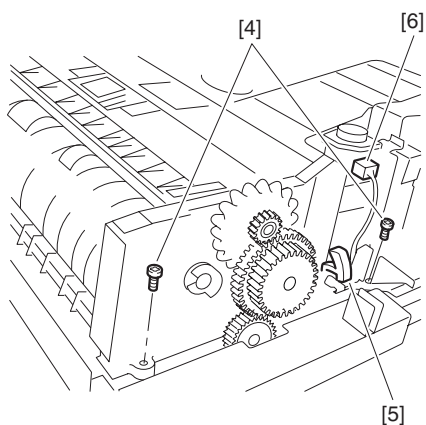

F-4-212

- 3) Disconnect the sensor connector [7].
- 4) Remove the 2 screws [7], and detach the feeder unit [89].

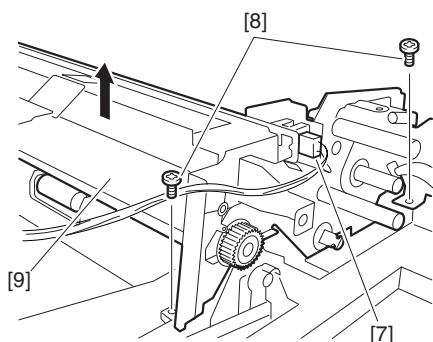

F-4-213

### 4.3.10.9 Removing the Lower Delivery Reversing Roller Unit

0001-1102

- 1) Remove the E-ring [2].
- 2) Remove the white plate (copyboard cover).

⚠ The white plate (copyboard cover) is attached to the frame using double-sided sponge tape (8 locations).

If you have detached it, be sure to attach it back in position using new double-sided sponge tape.

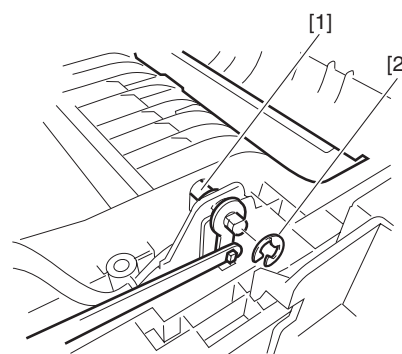

F-4-214

- 3) Pull out the bushing [3] by pulling on the claw; then, detach the lower delivery reversing roller unit [4].

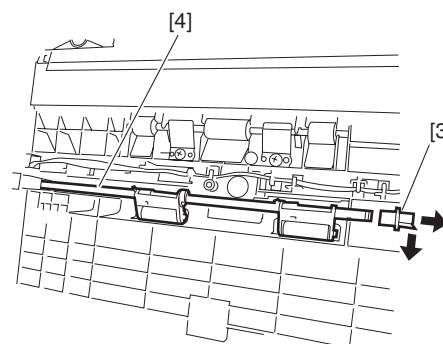

F-4-215

### 4.3.11 Read Roller Roll

#### 4.3.11.1 Removing the Read Roller 2 Roll

0001-1110

- 1) Remove the white plate (copyboard cover).

⚠ The white plate is attached to the frame using double-sided sponge tape (8 locations).

If you have detached it, be sure to attach it back in place using new double-sided sponge tape.

- 2) Remove the 2 screws [1], and detach the read roller 2 roll.

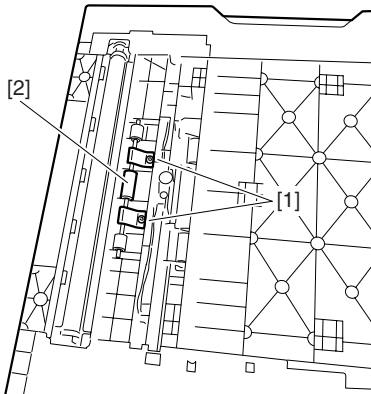

F-4-216

### 4.3.12 Separation Guide Sheet

#### 4.3.12.1 Before Replacing the Separation Guide Sheet

0002-0562

##### Before Replacing the Separation Guide Sheet

You will need a stubby screwdriver for replacement; if it is not available, detach the front cover and the feeder cover.

#### 4.3.12.2 Removing the Front Cover

0002-0563

- 1) Open the feeder cover [1], and remove the screw [2].

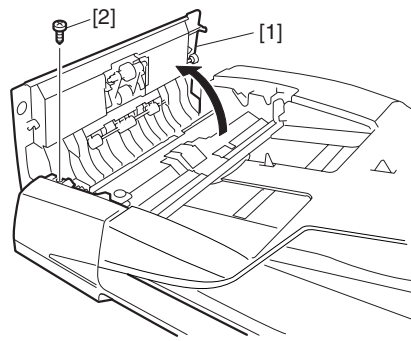

F-4-217

- 2) Remove the 2 screws [3], and detach the front cover [4].

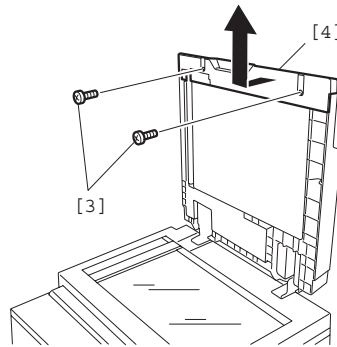

F-4-218

#### 4.3.12.3 Removing the Feeder Cover

0002-0566

- 1) Remove the screw [1] and the positioning pin [2]; then, detach the feeder cover [3].

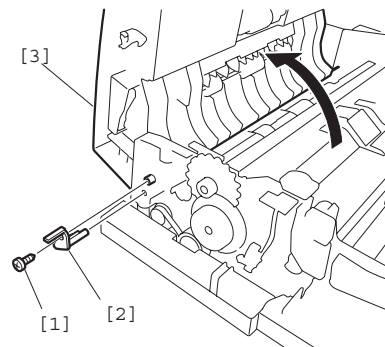

F-4-219

#### 4.3.12.4 Replacing the Separation guide Sheet 0001-1118

- 1) Open the separation guide.
- 2) Remove the 2 screws [1], and detach the guide fixing [2].  
You will need a stubby screwdriver to remove it.
- 3) Peel off the separation guide sheet [3]; then, clean the area left behind by the sheet and the area around it with lint-free paper moistened with alcohol.
- 4) Attach the new separation guide sheet [4] as shown.

**⚠** When attaching the sheet, be sure to butt it against the stop in both horizontal and vertical directions.

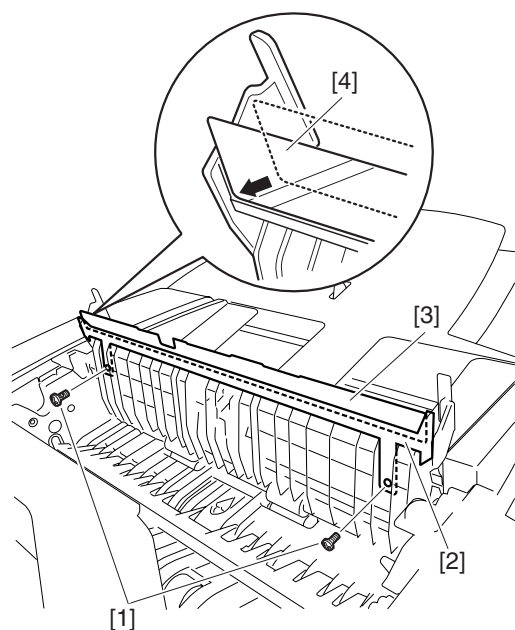

F-4-220

### 4.3.13 Feed Roller Guide

#### 4.3.13.1 Repacking the Feed Roll Guide (dust-collecting tape) 0001-7070

- 1) Open the ADF.
- 2) Remove the 2 screws [1], and detach the feed roll guide [2].

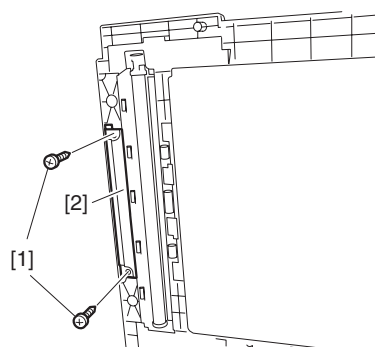

F-4-221

- 3) Mount the new feed roll guide.



## 4.4 Electrical System

### 4.4.1 ADF Controller PCB

#### 4.4.1.1 Removing the Rear Cover

0002-1461

- 1) Open the feeder cover and the original pickup tray; then, move the screw [1].

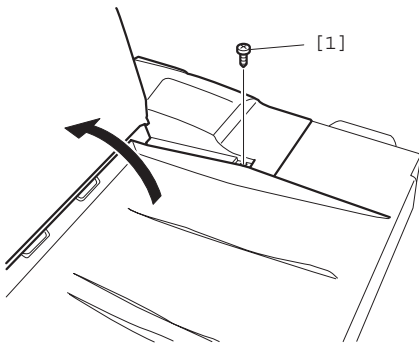

F-4-222

- 2) Remove the 2 screws [2], and detach the rear cover [3].

**⚠** Be sure to detach the cover while feeding the 3 claws [4] of the rear cover.

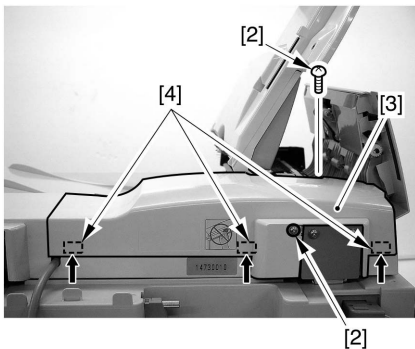

F-4-223

#### 4.4.1.2 Removing the ADF Controller PCB

0001-1142

- 1) Disconnect all connectors of the ADF controller PCB.

- 2) Remove the screw [1], and detach the ADF controller PCB.

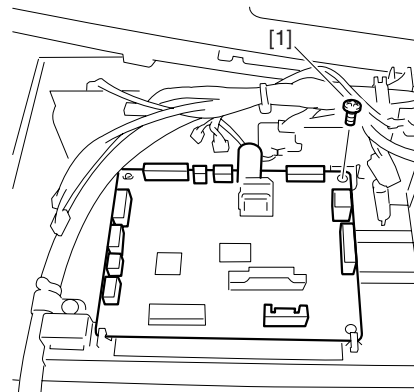

F-4-224

### 4.4.2 Inner Sensor of Feed Unit

#### 4.4.2.1 Removing the Front Cover

0002-1404

- 1) Open the feeder cover [1], and remove the screw [2].

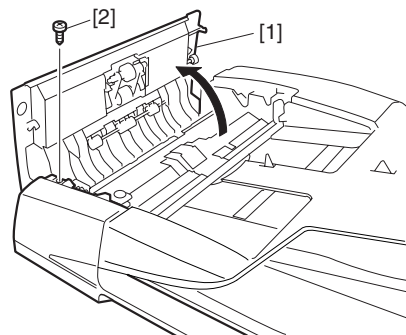

F-4-225

- 2) Remove the 2 screws [3], and detach the front cover [4].

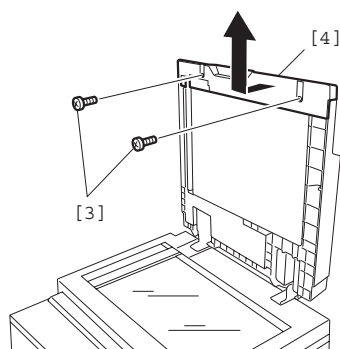

F-4-226

#### 4.4.2.2 Removing the Rear Cover

Cover

0002-1466

- 1) Open the feeder cover and the original pickup tray; then, move the screw [1].

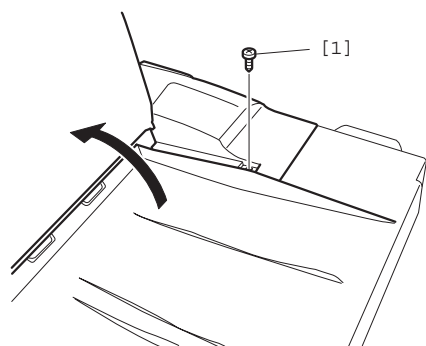

F-4-227

- 2) Remove the 2 screws [2], and detach the rear cover [3].

**⚠** Be sure to detach the cover while feeding the 3 claws [4] of the rear cover.

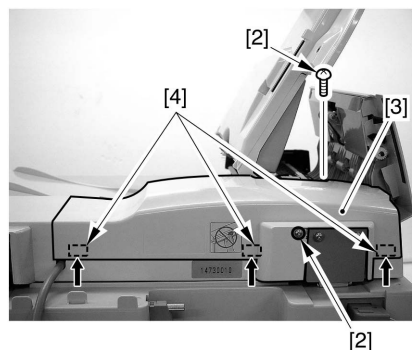

F-4-228

#### 4.4.2.3 Removing the Feeder Cover

Cover

0002-1407

- 1) Remove the screw [1] and the positioning pin [2]; then, detach the feeder cover [3].

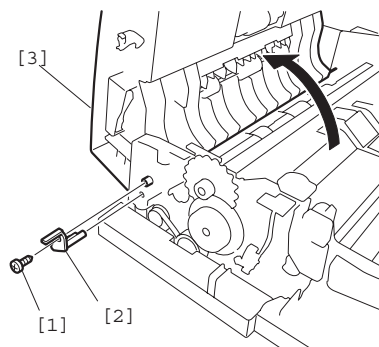

F-4-229

#### 4.4.2.4 Removing the Pickup Motor

Motor

0002-1408

- 1) Disconnect the connector [1].
- 2) Remove the 2 fixing screws [2] of the adjusting plate.

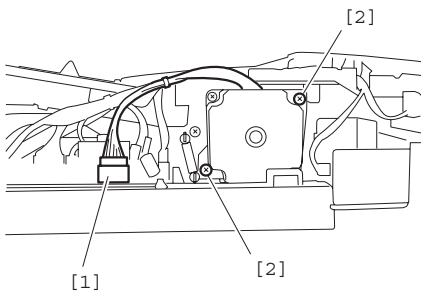

F-4-230

3) Remove the tension spring [3] using tweezers; then, remove the stepped screw [4], and detach the pickup motor [5] together with the adjusting plate.

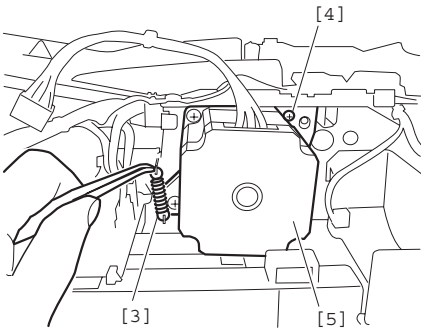

F-4-231

#### 4.4.2.5 Removing the Feeder

Motor

0002-1410

1) Free the 4 claws [1] of the harness guide; then, disconnect the connector [2].

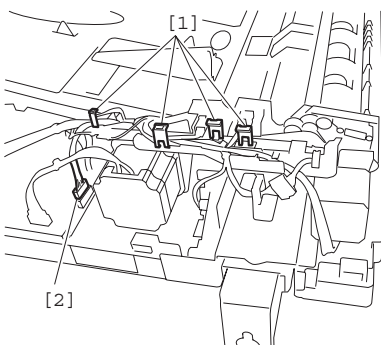

F-4-232

2) Remove the tension spring [3].

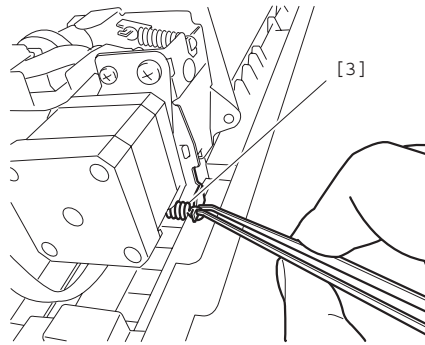

F-4-233

3) Remove the 2 screws [4] and the stepped screw [5]; then, detach the feed motor [6] together with the adjusting plate [7].

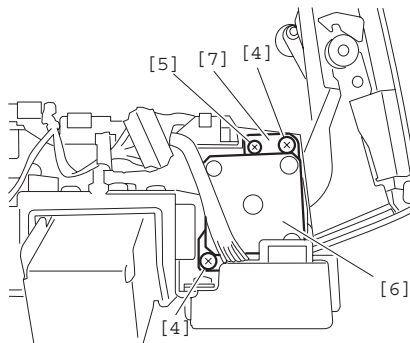

F-4-234

#### 4.4.2.6 Disassembling the Drive System

0002-1411

1) Disconnect the 2 connectors [1], and remove the screw [2] and the grounding fixing screw [3]; then, slide the harness guide slightly to the left, and lift it.

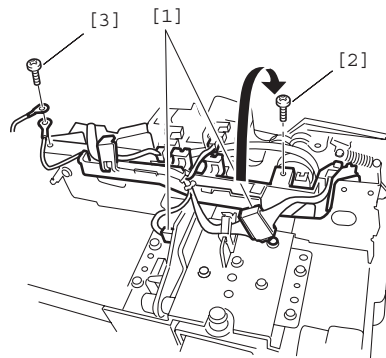

F-4-235

- 2) Remove the 4 screws [4] and the other screw [5]; then, detach the left hinge unit.

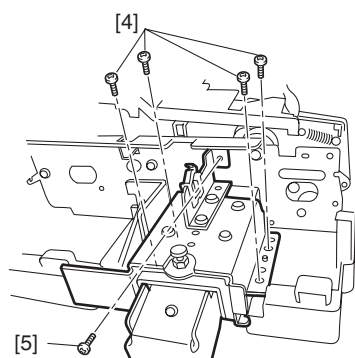

F-4-236

- 3) Remove the 3 screws [6] and the 2 other screws [7]; then, detach the motor base [8].

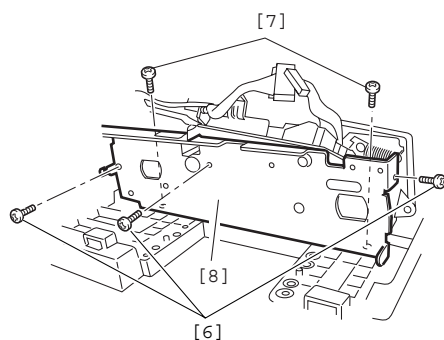

F-4-237

- 4) Detach the motor drive timing belt [9] [10].

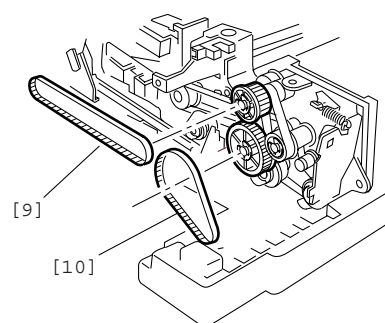

F-4-238

- 5) Remove the 3 E-rings [11], and detach the 2 pulleys [12], one-way clutch [13], and timing belt [14] [15].

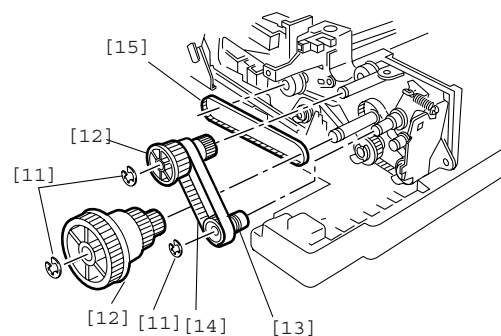

F-4-239

- 6) Remove the resin E-ring [16], and detach the pulley [17] and the timing belt [18]. You will have to remove the feeder unit when detaching the pulley [19].

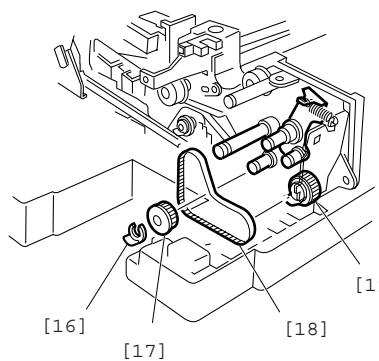

F-4-240

- ⚠ When attaching the timing belt [1], loosen the screw [21] of the tension arm [20]; then, force the arm counterclockwise to attach it. When you have attached the timing belt, tighten the screw [21].

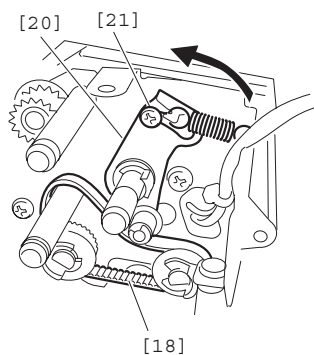

F-4-241

### 4.4.2.7 Removing the Feeder

Unit 0001-1146

- 1) Remove the screw [1], and pull out the busing [2]; then, detach the original pickup tray [3].

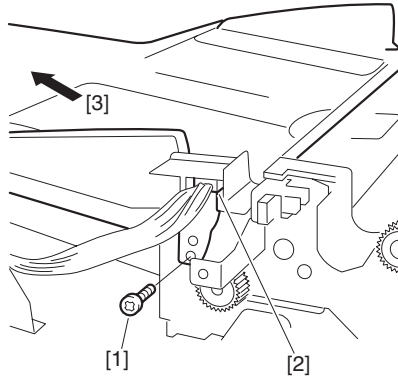

F-4-242

- 2) Remove the 2 screws [4] on the front cover side; then, remove the locking support [5], and disconnect the connector [6].

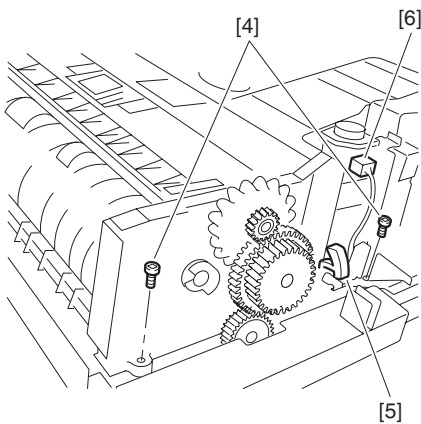

F-4-243

- 3) Disconnect the sensor connector [7].
- 4) Remove the 2 screws [7], and detach the feeder unit [89].

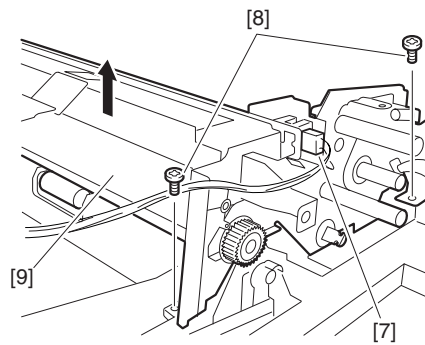

F-4-244

### 4.4.2.8 Removing the Upper Delivery Reversing Roller 0001-1151

- 1) Turn over the feeder unit; then, remove the resin E-ring [1], and pull out the pulley [2] and the bushing [3].

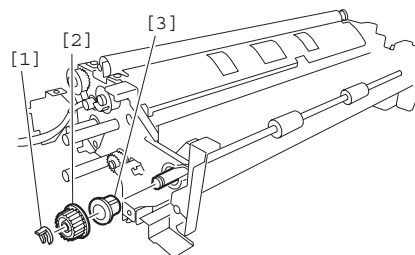

F-4-245

- 2) Remove the resin E-ring [4], and detach the bushing [5].
- 3) Remove the upper reversing delivery roller [6] and the separation guide [7].

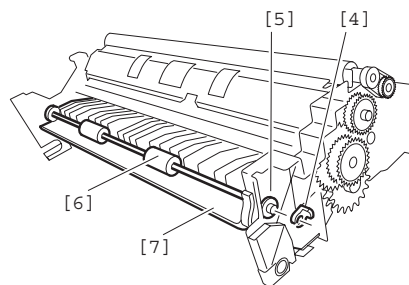

F-4-246

### 4.4.2.9 Removing the Platen

#### Guide L

0002-0555

- 1) Remove the 2 screws [1], and detach the platen guide L [2].

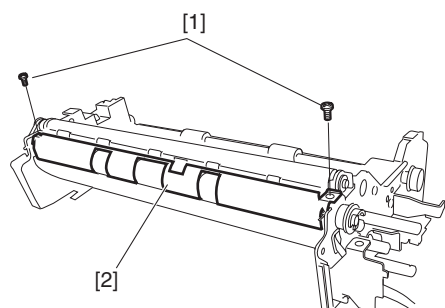

F-4-247

### 4.4.2.10 Removing the Reader

#### Roller 1

0001-1158

- 1) Remove the resin E-ring [1], and detach the pulley [2], timing belt [3], and bushing [4].

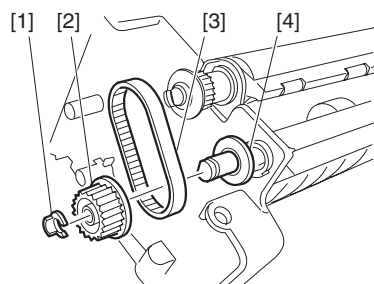

F-4-248

- 2) Remove the resin E-ring [5], and detach the pulley [6], and the bearing [7].

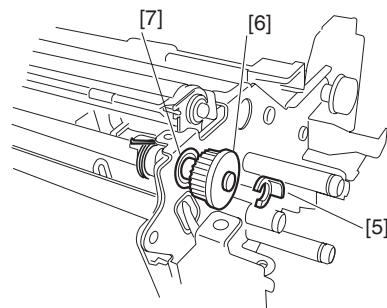

F-4-249

- 3) Remove the 2 resin E-rings [8], and detach the

reader roller 1 [9] as shown in the figure.

**⚠** Be sure to pull out the roller while keeping the sensor flag [1] out of the way.

**⚠** The platen roller [10] will come off together with the arm when the read roller 1 [9] is removed; take care not to misplace the spring [11] of the arm.

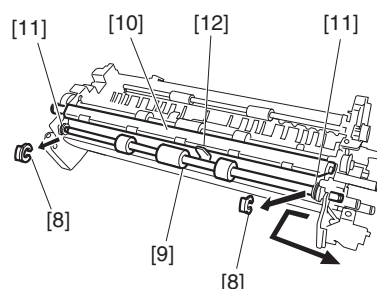

F-4-250

**⚠** When mounting the platen roller pressure spring (left, right) [13], be sure that the hook segment of the spring is on the outside of the platen guide L.

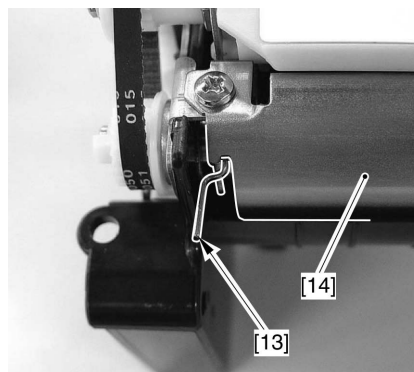

F-4-251

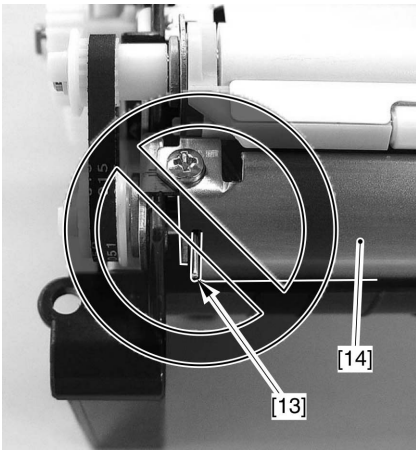

F-4-252

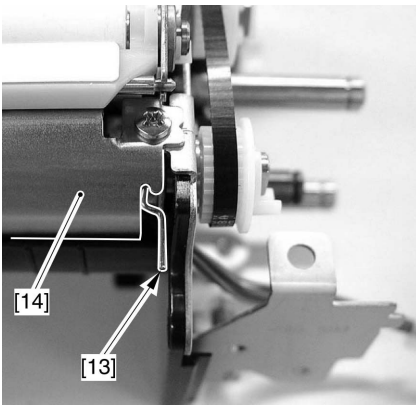

F-4-253

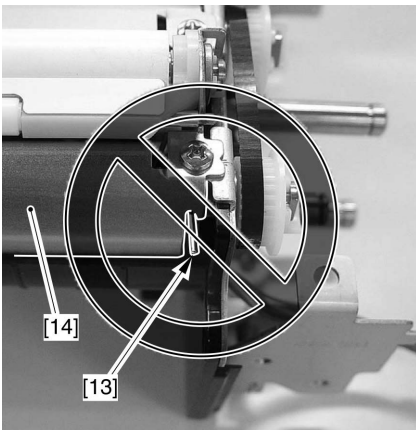

F-4-254

#### 4.4.2.11 Removing the Read

##### Roller 2

0001-1153

- 1) Remove the screw [1], and detach the platen guide R [2].

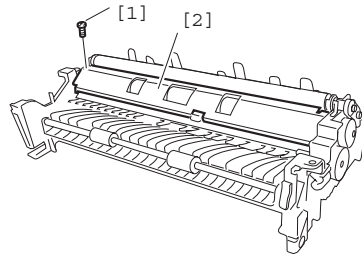

F-4-255

- 2) Remove the resin E-ring [3], and detach the pulley [4] and the bearing [5].

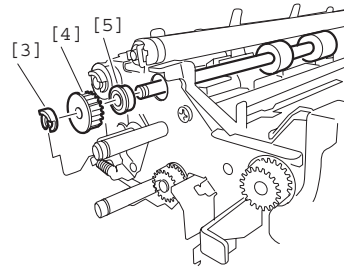

F-4-256

- 3) Remove the resin E-ring [6], gear [7], and bushing [8].

- 4) Lift the read roller 2 [9] along the space of the shaft opening as show; then, slide it to detach.

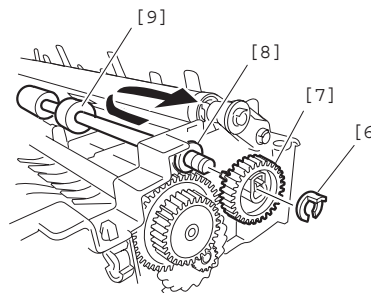

F-4-257

#### 4.4.2.12 Removing the Platen

##### Roller

0001-1155

- 1) Remove the resin E-ring [5]; then, detach the pulley

[6], timing belt [7], and bushing [8].

- 2) Remove the resin E-ring [9], and detach the bushing [10].

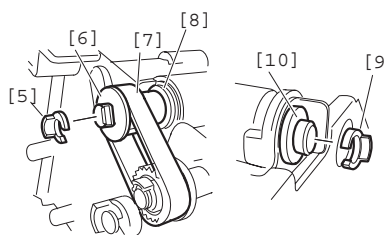

F-4-258

- 3) Detach the platen roller [11] as show together with the roller holder.

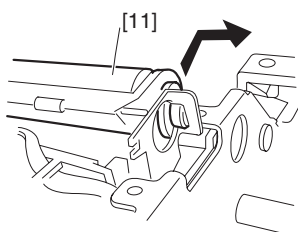

F-4-259

- 4) Detach the platen roller [11] from the roll holder.

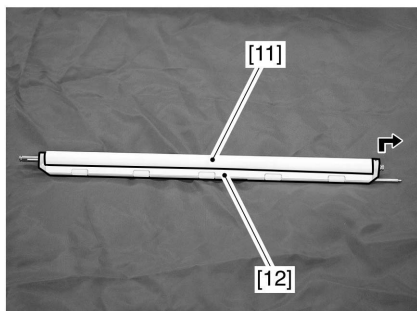

F-4-260

- ⚠** When mounting the platen roller [11], and the roll holder, be sure that the roll shaft [13] is fitted in the cut-off [14] of the base.

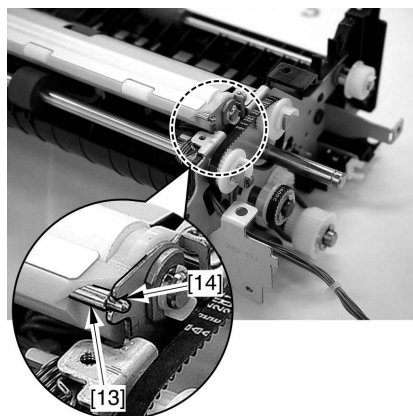

F-4-261

#### 4.4.2.13 Removing the Feeder

Unit Inside Sensor

[0001-1161](#)

- 1) Remove the 2 screws [1], and detach the sensor unit [2].

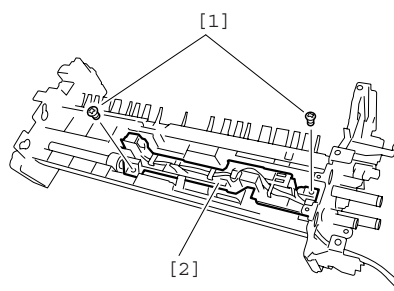

F-4-262

#### 4.4.3 Document Width Volume

##### 4.4.3.1 Removing the Front

Cover

[0001-1167](#)

- 1) Open the feeder cover [1], and remove the screw [2].



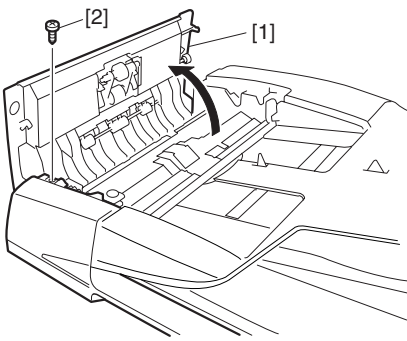

F-4-263

- 2) Remove the 2 screws [3], and detach the front cover [4].

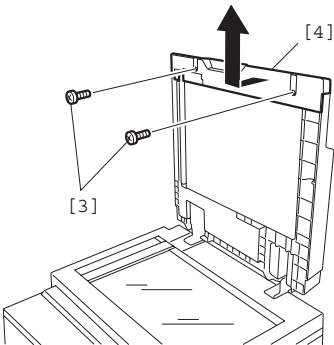

F-4-264

#### 4.4.3.2 Removing the Original Width Volume

0001-1171

- 1) Lift the original pickup tray.
- 2) Remove the 4 screws [1], and detach the cover [2].

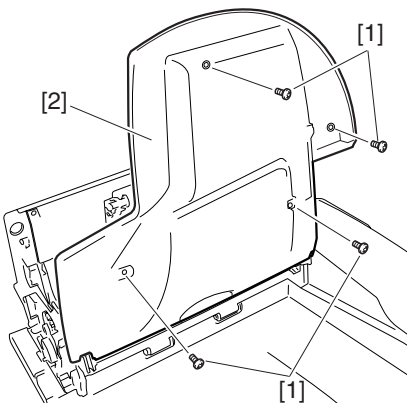

F-4-265

- 3) Disconnect the 2 connectors [3], and free the

harness [4] from the stack guide.

- 4) Remove the 2 screws [5], and detach the original width volume [6].

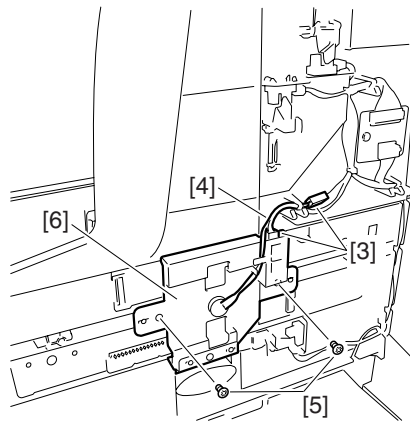

F-4-266

#### 4.4.3.3 Mounting the Original Width Volume

0001-1178

- 1) Spread the side guide [1] to its fullest.
- 2) Turn the gear [2] fully counterclockwise (viewing from the gear side); then, adjust and mount it so that the arrows [3] match.

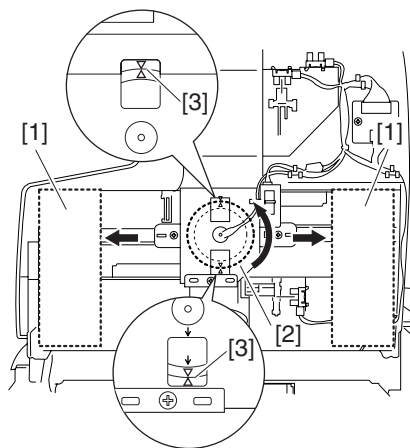

F-4-267

#### 4.4.4 ADF Open/Closed Sensor

##### 4.4.4.1 Removing the Open/Closed sensor

0001-1183

- 1) Remove the screw [1], and detach the sensor base

[2].

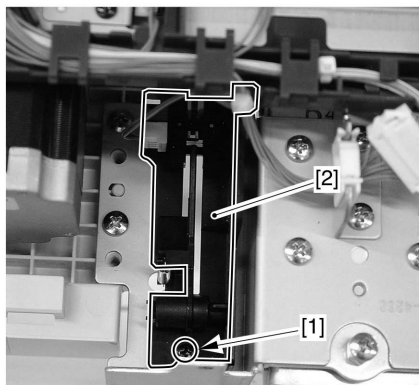

F-4-268

- 2) Disconnect the connector [3].
- 3) Detach the ADF open/closed sensor from the sensor base [4].

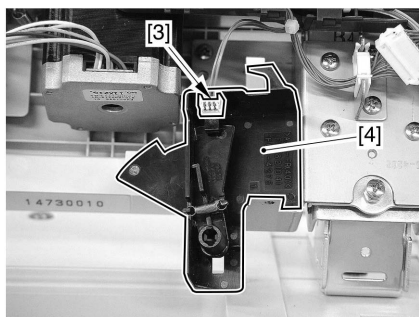

F-4-269

## 4.4.5 Cover Open/Closed Sensor

### 4.4.5.1 Removing the Rear Cover

0002-1463

- 1) Open the feeder cover and the original pickup tray; then, move the screw [1].

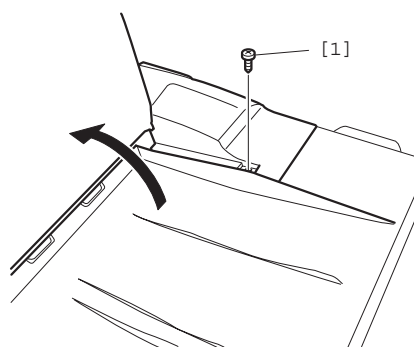

F-4-270

- 2) Remove the 2 screws [2], and detach the rear cover [3].

**▲** Be sure to detach the cover while feeding the 3 claws [4] of the rear cover.

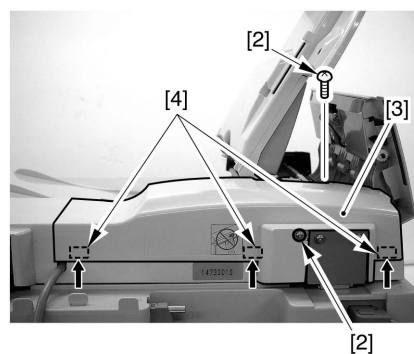

F-4-271

### 4.4.5.2 Removing the Cover Open/Closed Sensor

0001-1189

- 1) Disconnect the connector [1].
- 2) Remove the cover open/closed sensor [2].

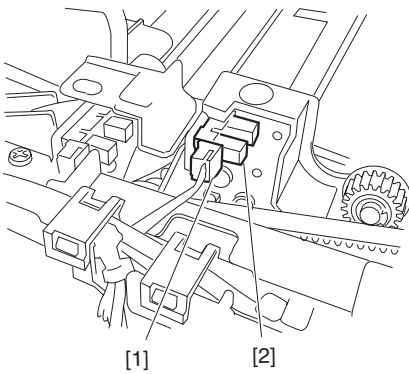

F-4-272

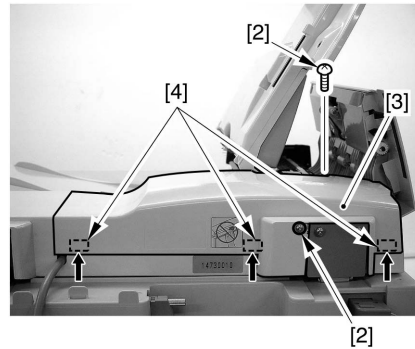

F-4-274

## 4.4.6 Document Set Sensor

### 4.4.6.1 Removing the Rear Cover

0002-1464

- 1) Open the feeder cover and the original pickup tray; then, move the screw [1].

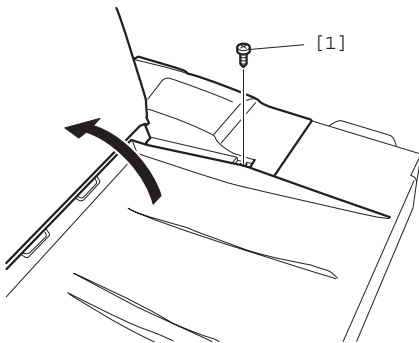

F-4-273

- 2) Remove the 2 screws [2], and detach the rear cover [3].

**⚠** Be sure to detach the cover while feeding the 3 claws [4] of the rear cover.

### 4.4.6.2 Removing the Original Placement Sensor

0001-1192

- 1) Remove the screw [1].
- 2) Remove the original placement sensor [2] together with the bracket; then, disconnect the connector [3].

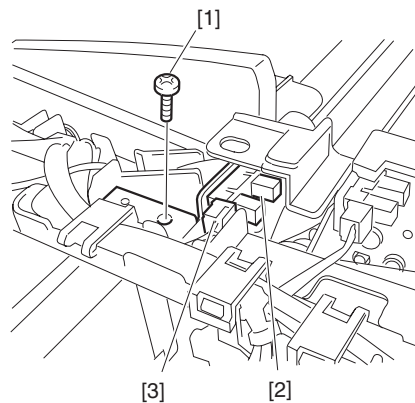

F-4-275

## 4.4.7 Pressurization Solenoid

### 4.4.7.1 Removing the Rear Cover

0002-1465

- 1) Open the feeder cover and the original pickup tray; then, move the screw [1].

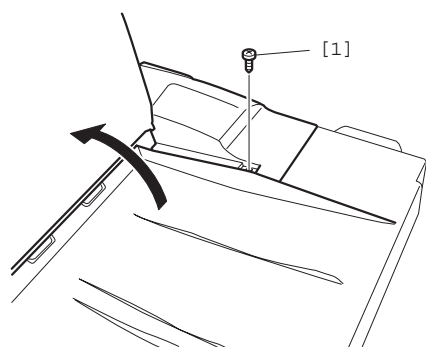

F-4-276

- 2) Remove the 2 screws [2], and detach the rear cover [3].

⚠ Be sure to detach the cover while feeding the 3 claws [4] of the rear cover.

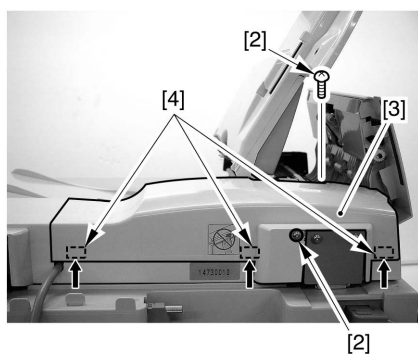

F-4-277

#### 4.4.7.2 Remove the screw [1], and detach the ADF controller PCB.

[0001-1196](#)

- 1) Disconnect all connectors of the ADF controller PCB.
- 2) Remove the screw [1], and detach the ADF controller PCB.

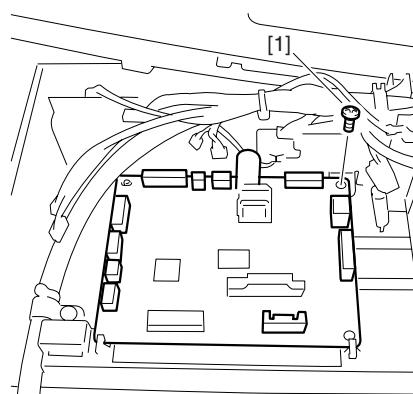

F-4-278

#### 4.4.7.3 Removing the Locking Solenoid

[0001-1197](#)

- 1) Remove the 2 screws [1], self-tapping screw [2], and the other screw [3]; then, detach the locking solenoid [4].

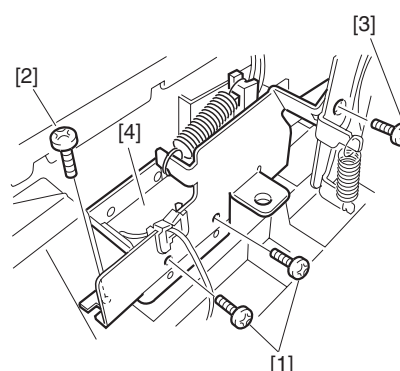

F-4-279

⚠ When mounting the locking solenoid, fit the plunger [5] to the arm [6] in advance; then, fit the locking solenoid [4] to the bracket.

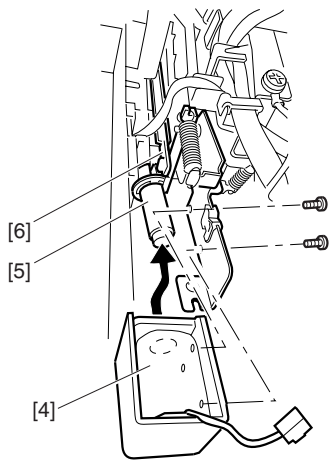

F-4-280

---

# Chapter 5 Maintenance

---



---

---

# Contents

5.1 User Maintenance .....	5-1
5.1.1 Cleaning .....	5-1
5.1.2 Replacement .....	5-2
5.2 Maintenance and Inspection .....	5-3
5.2.1 Periodically Replaced Parts .....	5-3
5.2.1.1 Periodically Replaced Parts .....	5-3
5.2.2 Durables .....	5-3
5.2.2.1 Durables .....	5-3
5.2.3 Periodical Servicing .....	5-3
5.2.3.1 Scheduled Servicing .....	5-3
5.2.4 Cleaning .....	5-6
5.2.4.1 ADF Components .....	5-6
5.2.4.2 Rollers and Guides .....	5-6
5.2.4.3 Applying Silicone Oil to the Reading Glass (copyboard glass) .....	5-9
5.3 Adjustment .....	5-11
5.3.1 Basic Adjustment .....	5-11
5.3.1.1 Overview .....	5-11
5.3.1.2 Adjusting the Tray Width .....	5-11
5.3.1.3 Adjusting the Height .....	5-12
5.3.1.4 Adjusting the Right Angles .....	5-14
5.3.1.5 Adjusting the Read Position .....	5-16
5.3.1.6 Adjusting the Magnification .....	5-16
5.3.1.7 Adjusting the Horizontal Registration .....	5-17
5.3.1.8 Adjusting the Trailing Edge Registration .....	5-17
5.3.1.9 Adjusting the White Level .....	5-18
5.3.2 Adjustment at Time of Parts Replacement .....	5-18
5.3.2.1 Adjusting the Side Guide Plate .....	5-18
5.4 Outline of Electrical Components .....	5-20
5.4.1 sensors .....	5-20
5.4.2 Motors, Clutches, Solenoids, PCBs, and Others .....	5-21
5.5 Variable Resistors (VR), Light-Emitting Diodes (LED), and Check Pins by PCB .....	5-22
5.5.1 Overview .....	5-22
5.5.2 ADF Controller PCB .....	5-22
5.5.3 Relay PCB .....	5-22
5.5.4 Original Placement LED PCB .....	5-23





## 5.1 User Maintenance

### 5.1.1 Cleaning

0001-5742

Advise the user to clean the following as necessary for every 10,000 prints without fail:

T-5-1

Item	Method	Intervals	Remarks
White plate (copyboard cover)	Wipe with a cloth moistened with water or alcohol; then, dry wipe it. Be sure that the cloth is well wrung.	As necessary	
Copyboard glass		As necessary, or every 10,000 prints	- parts in reader unit
Copyboard glass retainer		As necessary	- parts of reader unit
Vertical size plate		As necessary	- parts of reader unit

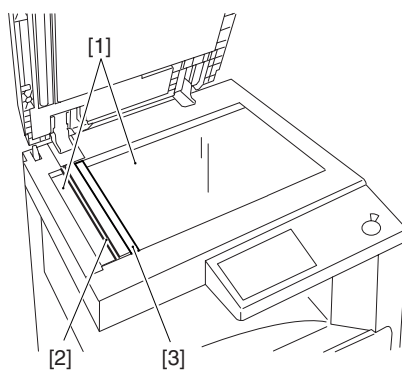

F-5-1

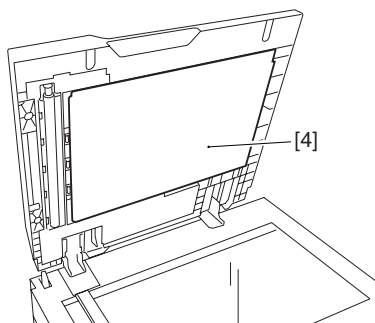

F-5-2

- [1] Copyboard glass
- [2] Copyboard glass retainer
- [3] Vertical size plate
- [4] White plate

## 5.1.2 Replacement

0001-6302

### 1. Replacing the Stamp

- 1) Open the feeder cover and the separation guide.
- 2) Detach the stamp using tweezers.
- 3) Fit a new stamp using tweezers. (Be sure that the stamping side faces upward.)

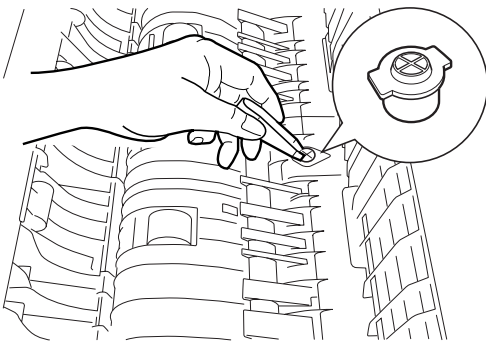

F-5-3

---

**⚠** Be sure to push in the stamp until a click is felt. Otherwise, jams can occur.

---

---

## 5.2 Maintenance and Inspection

---

### 5.2.1 Periodically Replaced Parts

#### 5.2.1.1 Periodically Replaced Parts

0001-5868

The machine does not have parts that must be replaced on a periodical basis.

### 5.2.2 Durables

#### 5.2.2.1 Durables

0001-5871

Some parts of the machine may need replacement once or more over the period of product warranty because of wear or damage. Replace them as necessary by referring to the following table (life expressed in terms of the number of originals picked up and checked in the machine's service mode):

T-5-2

as of August, 2003

No.	Parts name	Parts No.	Q'ty	Life	Remarks
1	Pickup roller	FM2-0787	1	80,000 sheets	may be checked in the host machine's service mode.
2	Separation pad	FL2-0963	1	80,000 sheets	separation roller (DF-FD-RL) separation pad (DF-SP-PD)
3	Feed roll guide	FL2-0946	1	40,000 sheets	(dust-collecting tape)

---

 The above values are estimates only and are subject to change based on future data.

---

### 5.2.3 Periodical Servicing

#### 5.2.3.1 Scheduled Servicing

0001-5946

 Do not use solvents/oils other than those indicated.

The presence of paper lint or dust on the roller or scraper can cause black lines in images. Be sure to clean them

carefully.

## T-5-3

Ref.	Parts name	Scheduled servicing		Remarks
		40,000 sheets	80,000 sheets	
1	White plate (copyboard cover)	clean		The number of prints expressing the use of the ADF may be checked in the host machine's service mode.
2	Platen roller	clean		
3	Registration roller, upper	clean		COPIER>COUNTER>FEEDER>FEED
4	Registration roller, lower	clean		
5	Read roller 2	clean		
6	Read roller 1	clean		
7	Read roller 1 roll	clean		
8	Read roller 2 roll	clean		
9	Delivery reversing roller, upper	clean		
10	Delivery reversing roller, lower	clean		
11	Pickup roller	clean	replace	
12	Separation pad	clean	replace	
13	Separation roller	clean	replace	
14	Separation plate	clean		
15	Original pickup tray	clean		
16	Separate guide (including sheet)	clean		
17	Open/close frame, open/close guide	clean		
18	Feed frame (including sheet)	clean		
20	Platen guide L	clean		
21	Platen guide R	clean		
22	Reversing flapper	clean		

Ref.	Parts name	Scheduled servicing		Remarks
		40,000 sheets	80,000 sheets	
23	Reversing left guide sheet	clean		
24	Feed guide (dust-collecting tape)	replace		
25	Registration roller sheet	clean		
26	White plastic sheet	clean		
27	Reading glass	lubricate		Apply silicone oil.
28	DADF height	adjust		

The following figure shows the locations of the parts that require scheduled servicing:

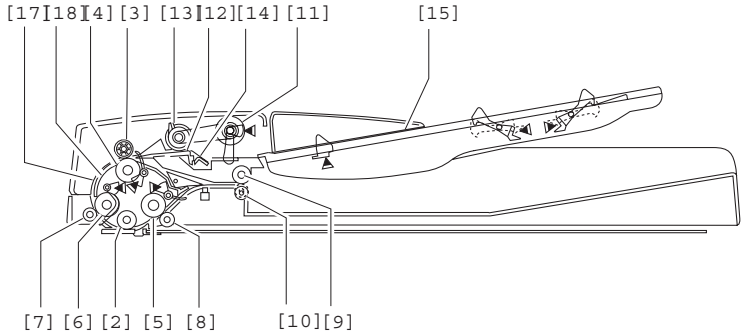

F-5-4

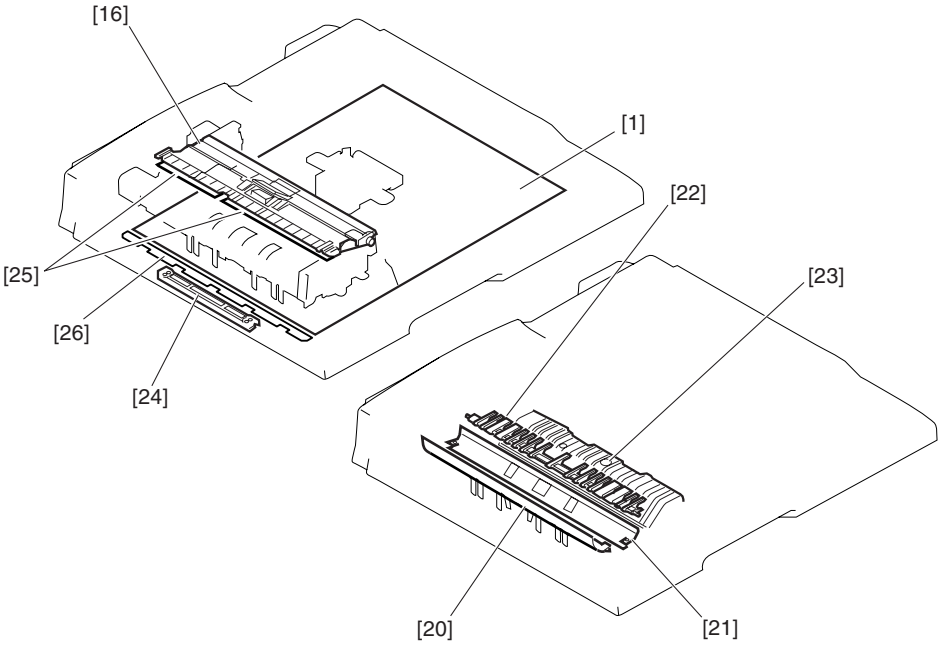

F-5-5

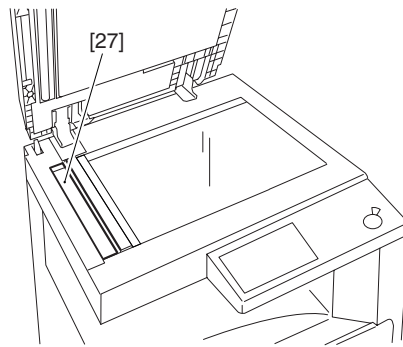

F-5-6

## 5.2.4 Cleaning

### 5.2.4.1 ADF Components

0001-5972

#### 1. Platen Roller

Wipe the platen roller [1] using a cloth moistened with water (well wrung) or alcohol; then, dry wipe it.

#### 2. White Plastic Sheet

Wipe the white plastic sheet [3] with a cloth moistened with water (well wrung) or alcohol; then, dry wipe it.

#### 3. White Plate (copyboard cover)

Wipe the white plate [2] with a cloth moistened with water (well wrung) or alcohol; then, dry wipe it.

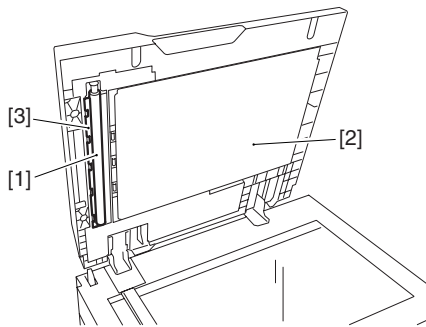

F-5-7

[1] Platen roller

[2] White plastic sheet

[3] White place

### 5.2.4.2 Rollers and Guides

0001-5979

#### 1. Original Pickup Tray

Clean the original pickup tray [1] using lint-free paper moistened with alcohol.

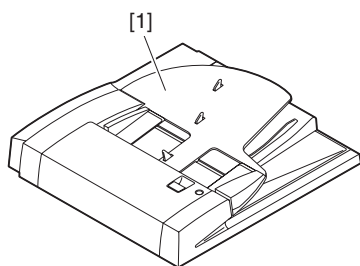

F-5-8

## 2. Pickup Roller and Separation Roller

- 1) Open the feeder cover.
- 2) Clean the pickup roller [1] and the separation roller [2] using lint-free paper moistened with alcohol.
- 3) Likewise, clean the back of the feeder cover and the area around the separation roller coming into contact with paper.

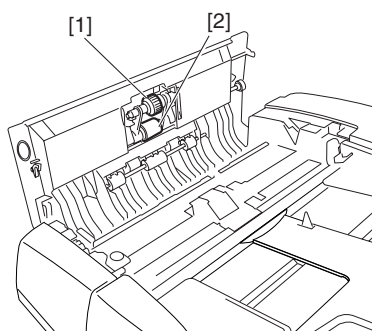

F-5-9

## 3. Separation Pad and Separation Plate

- 1) Open the feeder cover.
- 2) Clean the separation pad [1] and the separation plate [2] using lint-free paper moistened with alcohol.

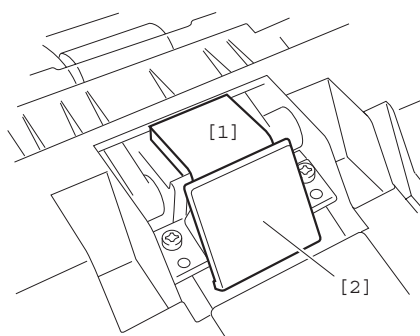

F-5-10

## 4. Upper registration Roller, Lower Registration Roller, and Separation Guide

- 1) Open the feeder cover and the separation guide.
- 2) Clean the upper registration guide [1] and the lower registration roller [2] using lint-free paper moistened with



alcohol.

- 3) Clean the top face and the bottom face of the separation guide, and clean the plastic sheet [3].

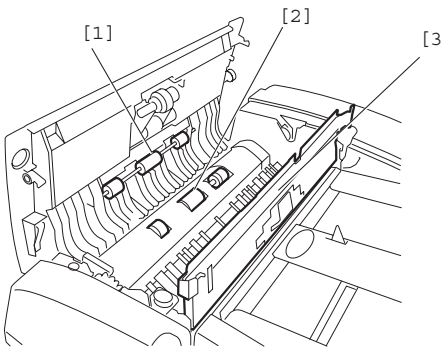

F-5-11

#### 5. Upper Delivery Reversing Roller and the Lower Delivery Reversing Roller

- 1) Remove the front cover.
- 2) Open the original pickup tray.
- 3) Turn the knob to rotate the upper delivery reversing roller [1] and the lower delivery reversing roller [2]; while doing so, clean them with lint-free paper moistened with alcohol.
- 4) Fit the front cover back on.

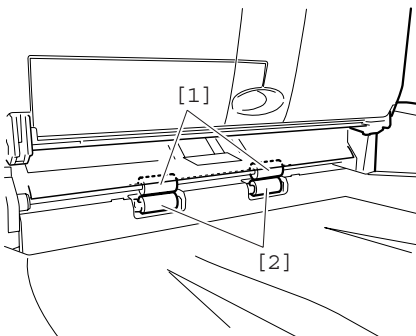

F-5-12

#### 6. Reversing Flapper

- 1) Open the feeder cover and the separation guide.
- 2) Clean the area of the reversing flapper where paper comes into contact using lint-free paper moistened with alcohol.

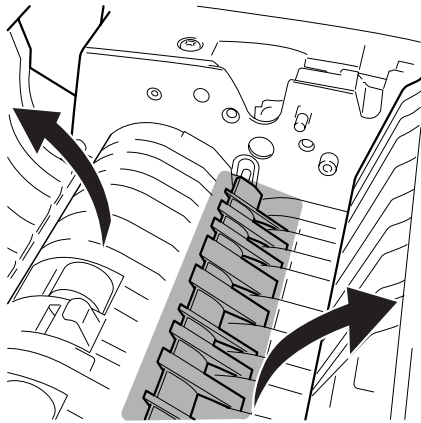

F-5-13

### 5.2.4.3 Applying Silicone Oil to the Reading Glass (copyboard glass)

0002-3244

#### 1. Items to Prepare

i. silicone oil

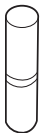

F-5-14

ii. cleaning tissue

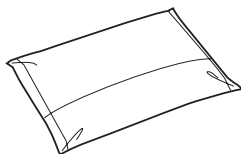

F-5-15

#### 2. Before Starting the Work

1) Cleaning the Reading Glass

- Dry-wipe the reading glass [1] using cleaning tissue.

⚠ Here, do not moisten the cleaning tissue with silicone oil as yet.

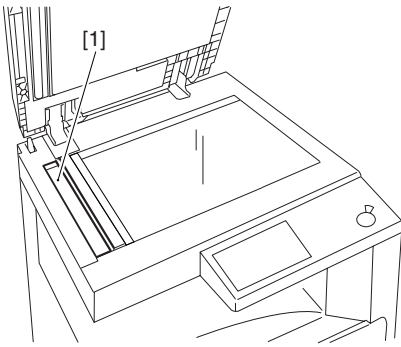

F-5-16

### 3. Applying Silicone Oil

1) Squeeze the silicone oil bottle [1] 2 to 3 times to moisten the cleaning tissue [2] with it.

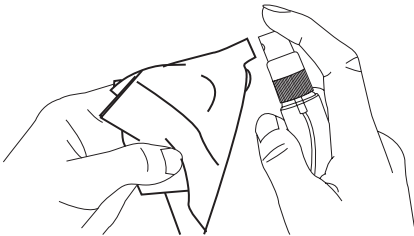

F-5-17

2) Apply silicone oil to the reading glass [1] with cleaning tissue. Thereafter, check to see that the glass has fully been cleaned.

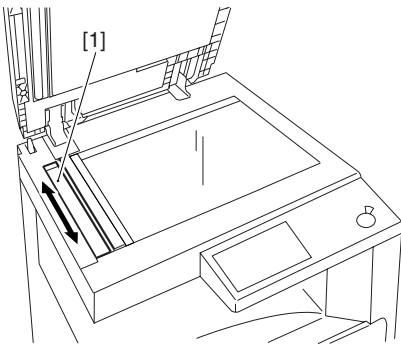

F-5-18

### 4. Cleaning with a dry tissue

1) Wipe the reading glass with a dry area of cleaning tissue (i.e., the area where silicon oil is not contained).

---

## 5.3 Adjustment

---

### 5.3.1 Basic Adjustment

#### 5.3.1.1 Overview

0001-5994

Go through the following in sequence:

- [1] tray width adjustment\*1
- [2] height adjustment
- [3] right angle adjustment
- [4] read position adjustment\*1
- [5] magnification adjustment\*1
- [6] horizontal registration adjustment\*1
- [7] trailing edge registration adjustment\*1
- [8] white level adjustment\*1

\*1: made from the hot machine's service mode.

#### 5.3.1.2 Adjusting the Tray Width

0001-6000

#### MEMO

The result of this adjustment is retained on the reader controller PCB. As such, unlike previous ADFs, you will need to make this adjustment at time of installation so that you will be able to store its result in the reader unit. If you omit this adjustment, the following will likely occur:

- wrong original size detection
- 
- 

 Adjust the tray width by performing either AB-configuration adjustment or inch-configuration adjustment.

---

#### 1. AB-Configuration Adjustment

##### 1) Start service mode.

Starting Service Mode

Press the User Mode key, press the 2 and 8 keys at the same time, and press the User Mode key once gain.

##### 2) Touch the following notations in sequence to bring up the Adjustment screen:

1 FEEDER

2 FUNCTION

3 TRY-A4 (to highlight)

##### 3) Adjust the tray side guide to the A4/A3 index.

##### 4) Touch [OK] to register the A4 width.

##### 5) Touch [TRY-A5R] to highlight.

##### 6) Adjust the tray side guide to the A5R index.

- 7) Touch [OK] to register the A5R width.
- 8) Press the Reset key twice to end service mode.
- 9) Turn OFF the power switch on the operation panel and main power switch of the host machine in order.
- 10) Turn ON the main power switch of the host machine.

## 2. Inch-Configuration Adjustment

- 1) Start service mode.

### Starting Service Mode

Press the User Mode key, press the 2 and 8 keys at the same time, and press the User Mode key once again.

- 2) Touch the following notations in sequence to bring up the Adjustment screen:

- 1 FEEDER
- 2 FUNCTION
- 3 TRY-LTR (to highlight)

- 3) Adjust the tray side guide to the LTR/11x17 index.
- 4) Press [OK] to register the LTR width.
- 5) Press [TRY-LTRR] to highlight
- 6) Adjust the tray side guide to the STMT/LTRR/LGL INDEX.
- 7) Touch [OK] to register the LTRR width.
- 8) Press the Reset key twice to end service mode.
- 9) Turn OFF the power switch on the operation panel and main power switch of the host machine in order.
- 10) Turn ON the main power switch of the host machine.

### 5.3.1.3 Adjusting the Height

0001-6017

#### 1. Making Pre-Checks

Check to see that that the original butting segment on the pickup side is in full contact with the copyboard glass at both front and rear when the DADF is closed.

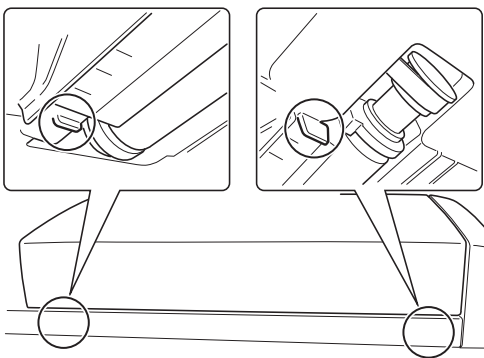

F-5-19

#### 2. Making Adjustments

- if the butting segment is not in contact at the front or the rear,
  - 1) adjust the left hinge (see 3)
  - 2) adjust the right hinge (see 4)

3) adjust the left hinge (see 3) or check the left hinge

- if the butting segment is not in contact at both sides

1) adjust the left hinge (see 3)

2) adjust the right hinge (see 4)

3) adjust the left hinge (see 3)

4) adjust the right hinge (see 4) or check the right hinge

3. Adjusting the Height of the Left Hinge

1) Turn the height adjusting screw [1] of the left hinge to make adjustments.

**⚠** Be sure to loosen the fixing nut [2] prior to the adjustment, and tighten it back after the adjustment.

- if the front side is not in contact, turn the adjusting screw clockwise so that the front will be in contact with the glass.

- if the rear or both sides are not in contact, turn the adjusting screw counterclockwise so that the rear will be in contact with the glass.

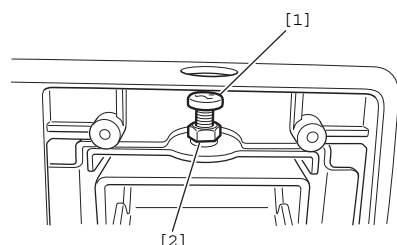

F-5-20

4. Adjusting the Height of the Right Hinge

1) Close the DADF, and check the following 2 points:

- the rubber foot [1] must not be in contact with the cover of the reader unit (i.e., there must be a gap, A).

- the original retaining sheet [2] is in contact with the copyboard glass.

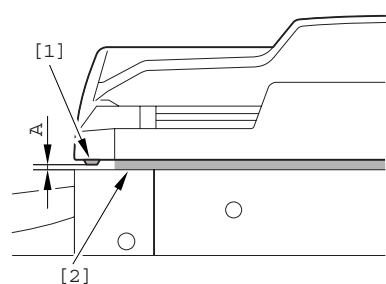

F-5-21

2) If the height is not correct, turn the height adjusting screw [1] of the right hinge to make adjustments.

**⚠** Be sure to loosen the fixing nut [2] prior to the adjustment, and tighten it back after the adjustment.

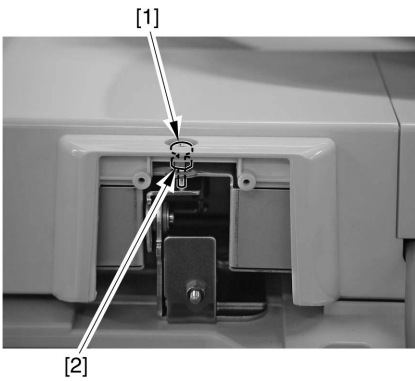

F-5-22

- turn the adjusting screw clockwise to increase the gap A.
  - turn the adjusting screw counterclockwise to decrease the gap A.
- 3) Make the checks indicated in sep 1) under "adjusting the height of the left hinge"; if a discrepancy is found, make adjustments once gain.

#### 5.3.1.4 Adjusting the Right Angles

0001-6029

- 1) Place a test chart in the DADF, and make a copy.
- 2) Check the right angles of the image along the leading edge of the copy. Specifically, check the difference between dimensions A and B of the leading edge; if there is a difference, go to step 3) to make adjustments.

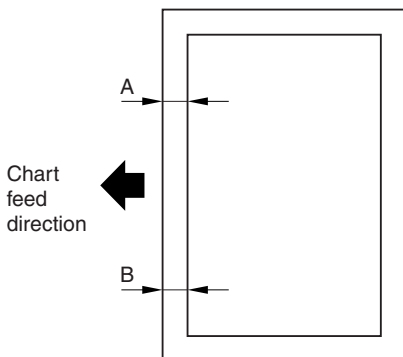

F-5-23

- 3) Loosen the 3 screws [1] used to fix the hinge in place.

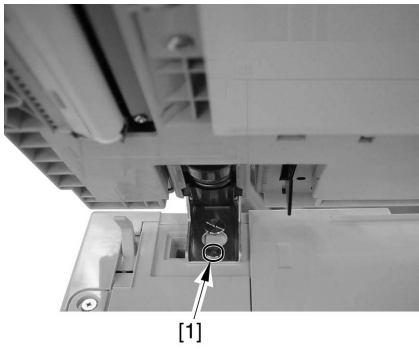

F-5-24

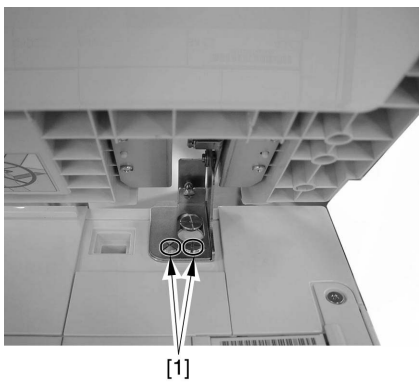

F-5-25

4) Turn the hinge adjusting screw [1] of the right hinge to adjust the angle of the DADF.

---

**⚠** Be sure to loosen the fixing nut [2] prior to the adjustment, and tighten it back after the adjustments.

---

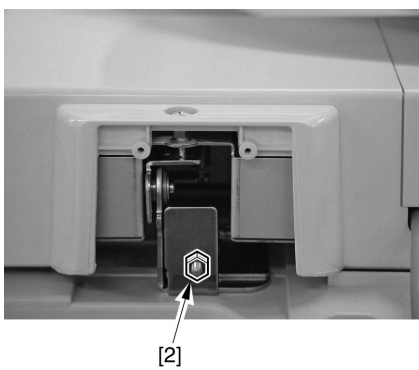

F-5-26



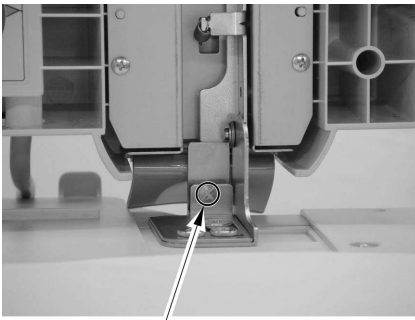

[1]

F-5-27

- If  $A > B$ , turn the adjustment screw clockwise.
- if  $A < B$ , turn the adjusting screw counterclockwise.
- 5) Tighten back all fixing screws you loosened in step 3).

### 5.3.1.5 Adjusting the Read Position

0001-6034

1) Start service mode.

[Starting Service Mode]

Press the User Mode key, press the 2 and 8 keys at the same time, and press the User Mode key once again.

2) On the Service Mode screen, touch the following notations in sequence to bring up the Adjustment screen:

- 1 COPIER
- 2 FUNCTION
- 3 INSTALL

3) Press [STRD-POS] to highlight.

4) Touch [OK].

A press on [OK] will cause the scanner to start a scan; in several seconds, the machine will end auto adjustment of the read position and indicate 'OK'.

---

**!** If the machine fails auto adjustment and indicates 'NG', go through the following:

- (1) Clean the white roller of the DADF and the copyboard glass of the host machine; then, execute auto adjustment once again.
- (2) If the auto adjustment operation still fails, start service mode, and make adjustments manually:  
COPIER>ADJUST>ADJ-XY>STRD-POS  
(The default is '30'. Try changing the setting, and check output copy images to decide on the best setting.)

---

### 5.3.1.6 Adjusting the Magnification

0001-6121

#### MEMO

The ADF's magnification is adjusted by comparing copy images made in stream reading mode and copy images

made in copyboard cover mode (as this ADF is designed for color machines; on the other hand, the magnification of previous ADFs designed for black-and-white machines is adjusted by comparing copy images made in stream reading mode against their originals). If you adjust its magnification in the way done for previous ADFs, the following will likely occur:

- wrong ACS identification
- wrong black character processing identification

- 
- 1) Place the Test Chart in the DADF, and make a copy. Refer to the output as copy B.
  - 2) Place the Test Chart used in step 1) on the copyboard glass of the host machine, and make a copy. Refer to the output as copy A.
  - 3) Compare copies A and B in terms of the length of the image in feed direction; as necessary, make adjustments in service mode.
    - if the image of copy B is shorter, decrease the setting (so that the speed at which originals are moved in stream reading mode will be reduced).
    - if the image of copy B is longer, increase the setting so that the speed at which originals are moved in stream reading mode will be increased).
- unit of adjustments: 0.1%

4) From the Service Mode screen, touch the following notations to bring up the Adjustment screen:

- 1 FEEDER
- 2 ADJUST
- 3 LA-SPEED to highlight

### 5.3.1.7 Adjusting the Horizontal Registration

0001-6123

- 1) Place the test chart in the DADF, and make a copy.
  - 2) Compare the copy against the Test Chart for the horizontal registration; as necessary, make the following adjustments:
    - if the image is displaced to the front, decrease the setting.
    - if the image is displaced to the rear, increase the setting.
- unit of adjustment: 0.1 mm

3) On the Service Mode screen, touch the following notations to bring up the Adjustment screen:

- 1 COPIER
- 2 ADJUST
- 3 ADJ-XY
- 4 ADJ-Y-DF

### 5.3.1.8 Adjusting the Trailing Edge Registration

0001-6124

- 1) Place the Test Chart in the DADF, and make a copy.
  - 2) Compare the copy against the Test Chart for the trailing edge registration; as necessary, make the following adjustments:
    - if the image is displaced to the leading edge, decrease the setting.
    - if the image is displaced to the trailing edge, increase the setting.
- unit of adjustment: 0.1 mm

3) On the Service Mode screen, touch the following notations to bring up the Adjustment screen:

- 1 FEEDER
- 2 ADJUST
- 3 DOCST

---

### 5.3.1.9 Adjusting the White Level

0001-6126

#### **MEMO**

This is a new item of adjustment in which the white level of images made in stream reading mode are matched with the white level of images made in copyboard cover mode (as this ADF is designed for color machines). If you omit this adjustment, the following will likely occur:

- inappropriate reproduction of background density in images made in stream reading mode
  - wrong speck detection in stream reading mode
- 

1) Place paper (of the type most often used by the user) on the copyboard glass, and close the DADF.

2) Touch the following notations in sequence to bring up the Adjustment screen:

- 1 COPIER
- 2 FUNCTION
- 3 CCD

3) Press [DF-WLVL1] to highlight.

4) Press [OK].

Automatic adjustment starts; if it ends successfully, the screen shows [OK!].

5) Remove the paper from the copyboard glass, and place it on the original tray of the DADF.

6) Press [DF-WLVL2] on the touch panel to highlight.

7) Press [OK].

- The machine executes auto adjustment (duplex stream reading).
- When the adjustment ends normally, the machine indicates 'OK!' on the screen.

8) Press the Reset key twice to end service mode.

### 5.3.2 Adjustment at Time of Parts Replacement

#### 5.3.2.1 Adjusting the Side Guide Plate

0001-7082

1) Remove the 4 mounting screws [1], and detach the cover [2].

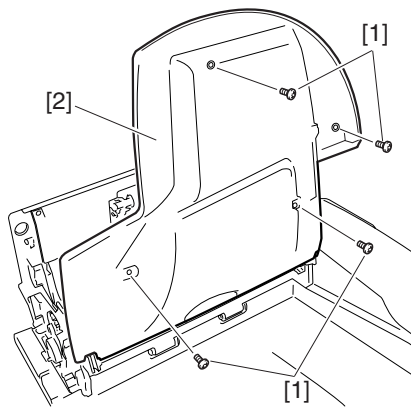

F-5-28

- 2) Loosen the mounting screws [3] [4]; then, move the original width volume unit [5] to the front or the rear to make adjustments.
- 3) Tighten the screws [3] [4].
- 4) Attach the cover after the adjustment.
- 5) Make a copy of the Text Chart once again to see that the resulting image is as indicated.

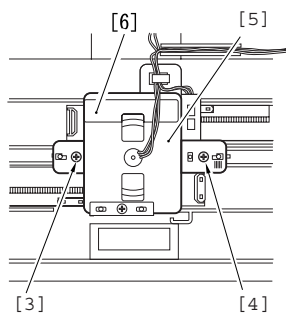

F-5-29

- if  $A > 1$  mm, move the volume unit [6] toward the front.
- if  $B > 1$  mm, move the volume unit [76] toward the rear.

## 5.4 Outline of Electrical Components

### 5.4.1 sensors

0001-6128

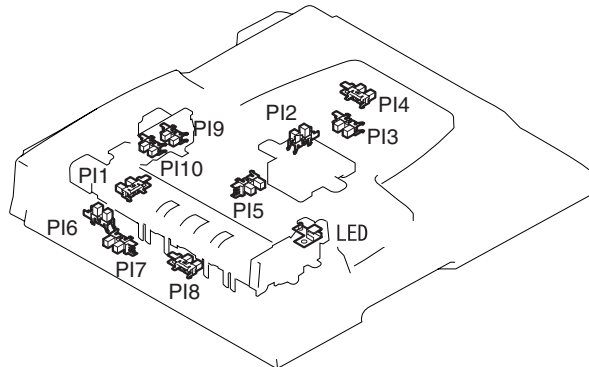

F-5-30

T-5-4

Name	Notation	Description
Photo-interrupter	PI1	ADF open/closed sensor
	PI2	registration paper sensor
	PI3	read sensor
	PI4	delivery reversal sensor
	PI5	A4R/LTRR identification sensor
	PI6	tray sensor 1
	PI7	tray sensor 2
	PI8	last-original sensor
	PI9	original placement sensor
	PI10	cover open/closed sensor
Original indicator LED	LED	indicates presence/absence of original

## 5.4.2 Motors, Clutches, Solenoids, PCBs, and Others

0001-6131

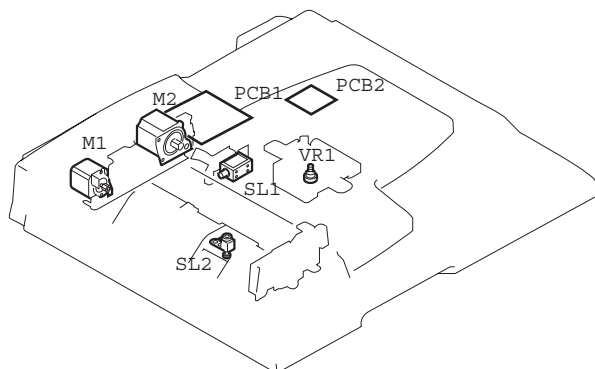

F-5-31

T-5-5

Name	Notation	Description
Motor	M1	feeder motor
	M2	pickup motor
Solenoid	SL1	stamping solenoid
	SL2	locking solenoid
ADF control PCB	PCB1	controls ADF
Relay PCB	PCB2	relays signals for sensor on original pickup tray
original width volume	VR1	identifies width of original

## 5.5 Variable Resistors (VR), Light-Emitting Diodes (LED), and Check Pins by PCB

### 5.5.1 Overview

0001-6136

Of the LEDs and check pins used in the machine, those needed in the field are discussed:

**⚠** Do not touch the check pins that are not indicated herein; they are for use at the factory and require high precision and special tools (including instruments).

### 5.5.2 ADF Controller PCB

0001-6137

Some LEDs emit dim light when they are off; this is a normal condition, and must be kept in mind.

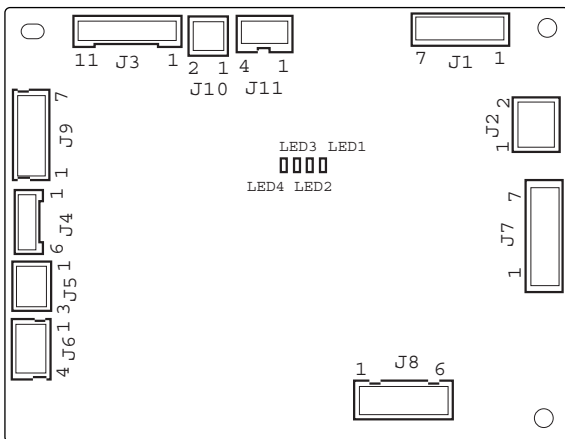

F-5-32

### 5.5.3 Relay PCB

0001-6138

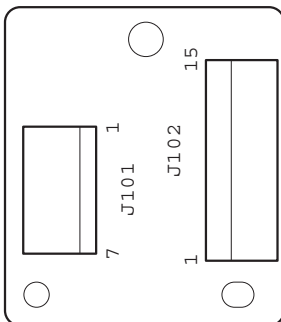

F-5-33

### 5.5.4 Original Placement LED PCB

0001-6318

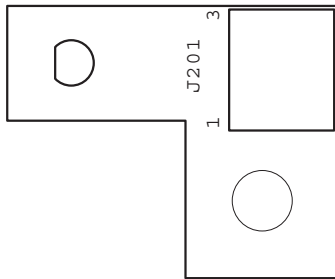

F-5-34





---

# Chapter 6 Error Code

---



# Contents

6.1 Overview .....	6-1
6.1.1 Overview .....	6-1
6.2 User Error Code.....	6-2
6.2.1 Alarm.....	6-2



## 6.1 Overview

### 6.1.1 Overview

0001-6335

The CPU on the machine's ADF control PCB is equipped with a mechanism to run a self check, which will flash the Original Placement indicator upon detection of a fault and communicate to the host machine by means of code. The communication may be any of the following 3 types, each causing the Original Placement indicator to flash in its own way:

T-6-1

Error type	Original Placement indicator
Alarm	flashes at intervals of 240 msec
Jam	flashes at intervals of 160 msec
Error	flashes at intervals of 80 msec

The code used for an alarm and jam may also be checked using the service mode of the host machine; in the presence of an error, the displays of the host machine will indicate a specific error code:

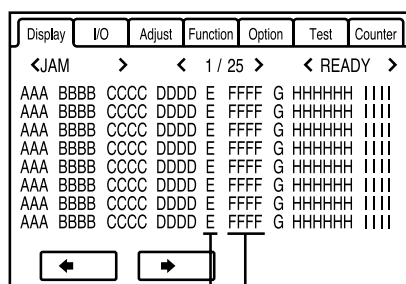

See descriptions for 02-301-01 and onward.  
The notation [1] stands for a jam occurring inside the machine.

F-6-1

## 6.2 User Error Code

### 6.2.1 Alarm

0001-6345

You can check the codes used for different alarms using the service mode of the host machine.

T-6-2

Display code	Error description	Machine operation	Host machine operation	Resetting
03xx	The machine has failed to separate the 1st original. (read sensor delay jam, or original registration sensor delay jam)	Stops operation, and flashes the Original Placement indicator.	Stops.	Remove the original, and put it back on.
11xx	At time of jam recovery, the tray runs out of originals before as many originals as there were have been circulated.	Stops operation, and flashes the Original Placement indicator.	Stops.	Put all originals back into place.
13xx	An original is pulled out; yet the read sensor is off even though the preceding original has been moved to the read position.	Stops operation, and flashes the Original Placement indicator.	Stops.	Remove the originals, and put them back in place.

Nov 13 2003



**Canon**